

UNIPROTECT 80/24 C - 160/24C



FR

Protection de batterie tension basse

p. 2-23

EN

Low voltage battery protection

p. 24-44

TABLE DES MATIERES

1.	Description et fonctionnement	
1.1.	Généralités	
1.2.	Fonctionnalités	
1.3.	
2.	Mise en œuvre	
2.1.	Installation	
2.2.	Fixation	
2.3.	Précautions	
2.4.	Conseils d'installation	
3.	Panneau de contrôle	
4.	Données techniques	
5.	Schémas de raccordement	
5.1.	Conseils de raccordement	
5.2.	Schéma complet	
5.3.	Schéma avec commande à distance (REMOTE)	
5.4.	Schéma avec commande d'un convertisseur DC-AC (UNIPOWER)	
5.5.	Schéma de câblage d'un organe d'alarme (ALARM)	
5.6.	Schéma avec plusieurs Uniprotect en protection	
5.7.	Schéma avec utilisation de la borne (IGNITION)	
5.8.	Schéma avec utilisation de la borne (EMERGENCY)	
6.	Programmation	
6.1.	Choix de la programmation	
6.2.	Programmation simplifiée	
6.3.	Programmation avancée	
6.4.	Réglage d'usine	
7.	Historique via Uniapp	
8.	Fonction spécifique - Contrôle d'un chargeur de batterie	
9.	Annexe	
9.1.	Pictogrammes	
9.2.	Avertissements	
9.3.	Anomalies, Causes, solutions	
9.4.	Garantie	

Cher client, nous vous remercions de votre achat pour l'un de nos produits Uniteck. Veuillez prendre connaissance avec attention de toutes les instructions avant d'utiliser le produit.

1. DESCRIPTION ET FONCTIONNEMENT

1.1. Généralités

Uniprotect est un interrupteur électronique de puissance unidirectionnel asservi en tension ce qui lui permet d'ouvrir ou de fermer une connexion électrique DC 12 ou 24V, sans formation d'étincelles.

Il est doté de composants de dernière génération permettant des performances inégalées par rapport au produit actuel du marché avec de très faibles chutes de tension.

Sa carte électronique complètement protégée lui permet de résister à des ambiances humides ou des vibrations mécaniques.

Uniprotect possède un réglage simple et précis avec plus de 200 réglages à réaliser via un afficheur. Une sortie alarme est disponible pour indiquer une situation critique et avertir l'utilisateur du système.

Un historique d'utilisation de plus de 500 jours, via l'application Uni App permet de fournir et d'analyser des données en cas de besoin.

Son mode Basse consommation assure une très faible auto décharge.

1.2. Fonctionnalités

Uniprotect est un contrôleur de décharge pour les batteries 12 ou 24V avec détection de tension batterie (12 ou 24V) automatique.

Il est asservi en tension et déconnectera les consommateurs non essentiels de la batterie en cas de tension basse à un niveau pré programmé ou en cas de danger pour les consommateurs (sur tension par exemple). Uniprotect fait en sorte que votre batterie garde suffisamment d'énergie, par exemple pour démarrer un véhicule ou pour d'autres opérations sensibles. Il protège également votre batterie contre les décharges profondes susceptibles d'endommager et d'accélérer le vieillissement de votre batterie.

Uniprotect intègre une borne spécifique permettant le contrôle d'un convertisseur Unipower PRO avec un mode de réglage permettant de prioriser le délestage. Il est possible de décaler la coupure du convertisseur soit avant soit après la tension de déconnexion.

Via les différents paramètres, il est possible d'utiliser votre Uniprotect en mode EMERGENCY afin de connecter les consommateurs pendant 4 minutes pour des mesures d'urgence lorsque le produit est en protection.

Uniprotect peut être également utilisé en mode Timer pour déconnecter des consommateurs après l'arrêt d'un véhicule via la borne IGNITION.

Uniprotect peut également servir pour contrôler des chargeurs de batterie électronique à distance et permet également un contrôle de surtension.

2. MISE EN OEUVRE

2.1. Installation

Uniprotect doit être installé dans un local bien ventilé, à l'abri de la pluie et de la poussière.

Grâce à son résinage, Uniprotect a été conçu pour être utilisé dans des conditions extrêmes. Cependant, la partie connectique nécessite une utilisation protégée de la pluie ou de projections d'eau.

2.2. Fixation

Afin d'assurer le refroidissement du produit, prévoyez un espace libre de 5 cm minimum tout autour du produit.

De préférence, le fixer sur une paroi verticale.

Tout autre méthode de fixation entrainera une baisse de performance de l'ordre de 10 à 20%.

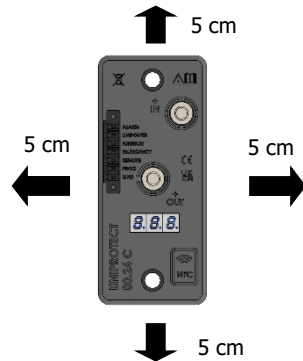

2.3. Précautions

Ne pas installer Uniprotect au dessus des batteries.

Toujours installer le dispositif Uniprotect proche de la batterie (<50 cm) afin d'éviter les chutes de tension dans les câbles.



Une chute de tension sur un câble sous-dimensionné ou trop long entre le pôle de la batterie et Uniprotect peut déclencher une alarme ou un arrêt imprévu.

2.4. Conseils d'installation



Uniprotect nécessite une masse commune entre le parc de batteries et les consommateurs.

Un fusible correctement dimensionné doit être installé entre la batterie et Uniprotect conformément aux réglementations en vigueur.

Les charges/consommateurs doivent être installées **après** la programmation complète du contrôleur de décharge Uniprotect.

Il est conseillé d'utiliser des sections de câbles adaptées pour les différentes connexions de puissance et de limiter les longueurs au maximum.

Conseil sur la section minimale de câble à utiliser:

Courant	Longueur de câble < 0,5 m	Diamètre des cosses	
		UNIPROTECT 80.24 C	UNIPROTECT 160.24 C
< 50 A	16 mm ²	M6 Couple de serrage recommandé 5 Nm	M8 Couple de serrage recommandé 9 Nm
Entre 50 et 100 A	25 mm ²		
Entre 100 et 150 A	35 mm ²		
Entre 150 et 250 A	50 mm ²	N.a.	
> 250 A	70 mm ²		

Uniprotect a été conçu pour un sens de circulation du courant de l'entrée + IN vers la sortie + OUT UNIQUEMENT. Un courant inversé de la sortie + OUT vers l'entrée + IN est strictement interdit et endommage l'appareil. Dommage non couvert par la garantie.

Si vous connectez des charges avec des condensateurs (Ex: Convertisseur DC-AC), Uniprotect peut se mettre en protection courts-circuit. Cependant, la gamme UNIPOWER PRO est connectable directement grâce à son démarrage SOFT START.

Pour contrôler à distance un convertisseur d'une autre marque ou un UNIPOWER, utilisez la borne spécifique "Unipower" de votre Uniprotect si celle ci est compatible.

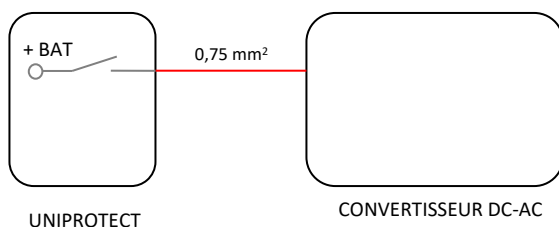

3. PANNEAU DE CONTRÔLE

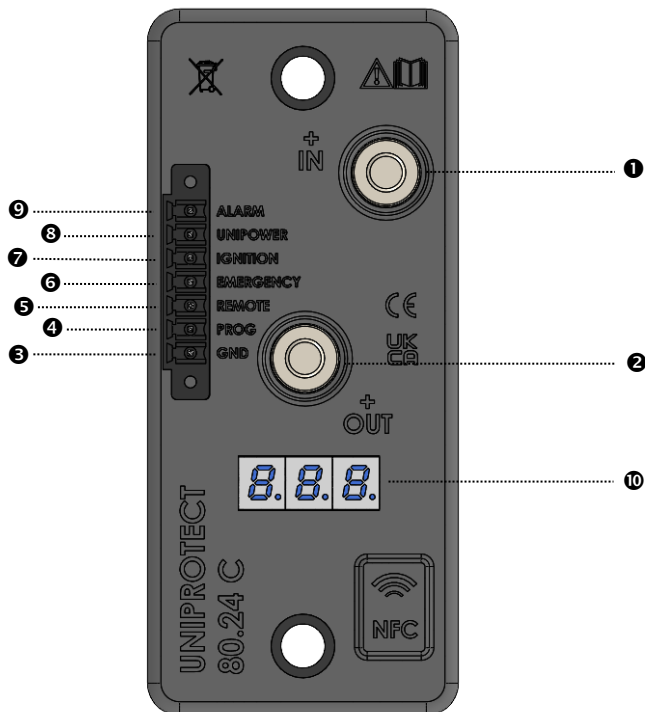

- 1** + IN : Pôle positif de la batterie.
Ne connecter qu'un seul câble.
- 2** + OUT : Pôle positif des consommateurs.
Ne connecter qu'un seul câble.
- 3** GND : Référence de tension négative. Relier cette borne au pôle négatif de la batterie grâce à un fil de section 0,75 à 1,5 mm². Ne raccorder aucun autre équipement.
- 4** PROG : Broche de programmation
- 5** REMOTE : Permet le contrôle de la sortie +OUT via un interrupteur externe.
- 6** EMERGENCY : Force la connexion des consommateurs durant 4 minutes si la tension de la batterie est et reste supérieure à 8,5V/17V. **Pas de protection de tension pendant l'utilisation de ce mode.**
- 7** IGNITION : Permet de déconnecter les consommateurs d'un véhicule en prenant en compte l'arrêt du moteur avec une temporisation préprogrammée
- 8** UNIPOWER : Permet la commande ON/OFF de consommateurs AC via un Unipower PRO.
- 9** ALARM : Possibilité de connecter le pôle négatif d'un voyant LED, un buzzer ou un relais. (Imax : 500 mA, protection contre le courtcircuit).
- 10** Afficheur de Programmation : permet l'affichage des différents modes
- Afficheur de l'Etat de la sortie :
- Sortie ON : Flash 1 point toutes les 10 secondes
 - Sortie OFF : Eteint en permanence
 - Sous tension : Flash L points toutes les 10 secondes
 - Sur tension : Flash H points toutes les 10 secondes
 - Surchauffe : Flash OH toutes les 10 secondes
 - Court-circuit : Flash SC toutes les 2 secondes

TABLE DES MATIERES

1.	Description and function
1.1.	General
1.2.	Functionalities
...	
2.	Setting Up
2.1.	Installation
2.2.	Mounting
2.3.	Precautions
2.4.	Installation instructions
3.	Control panel
4.	Technical data
5.	Connection diagrams
5.1.	Connection advice
5.2.	Complete diagram
5.3.	Diagram with remote control (REMOTE)
5.4.	Diagram with DC-AC inverter control (UNIPOWER)
5.5.	Wiring diagram for an Alarm unit (ALARM)
5.6.	Diagram with several uniprotect protection units
5.7.	Diagram Using the Ignition terminal (IGNITION)
5.8.	Diagram using emergency terminal (EMERGENCY)
6.	Programming
6.1.	Choice of programming
6.2.	Simplified programming
6.3.	Advance programming
6.4.	Factory setting
7.	History via Uniapp
8.	Special function – battery charger control
9.	Appendices
9.1.	Pictograms
9.2.	Warning
9.3.	Defects, causes, solutions
9.4.	Warranty

Dear customer, thank you for purchasing one of our Uniteck products. Please read all instructions carefully before using the product.

1. DESCRIPTION AND FUNCTIONS

1.3. General information

Uniprotect is a unidirectional electronic power switch with voltage control, enabling it to open or close a 12V or 24V DC electrical connection without generating sparks. It is equipped with cutting-edge components, providing unmatched performance compared to current market products, with very low voltage drops.

The fully protected electronic board makes it resistant to humid environments and mechanical vibrations. Uniprotect offers simple and precise adjustments, with over 200 settings configurable via a display interface. It also includes an alarm output to indicate critical situations and alert the system user. Additionally, a usage history of over 500 days can be accessed and analyzed via the Uni App.

Its low-consumption mode ensures very low self-discharge.

1.4. Features

Uniprotect is a discharge controller for 12 or 24V batteries with automatic voltage detection (12 or 24V).

It is voltage-controlled and will disconnect non-essential load/ electrical appliances from the battery in the event of low voltage at a pre-programmed level, or in the event of danger to electric appliances (e.g. overvoltage).

Uniprotect ensures that the battery retains enough energy for critical functions like starting a vehicle or supporting sensitive operations. It also protects your battery against deep discharges, which can damage and accelerate battery ageing.

Uniprotect incorporates a specific terminal for controlling a Unipower PRO inverter, with a setting mode for prioritizing load shedding. The inverter can be switched off either before or after the disconnection voltage.

Via the various settings, it is possible to use your Uniprotect in EMERGENCY mode to connect load for 4 minutes for emergency measures situations while the product is in protection mode.

Uniprotect can also be used in Timer mode to disconnect load after a vehicle has stopped via the IGNITION terminal.

With its remote-control features, it enables the remote management of electronic battery chargers and provides overvoltage protection.

2. SETTING UP

2.1. Installation

Uniprotect must be installed in a well-ventilated area, protected from rain and dust.

Thanks to its resin coating, Uniprotect is designed for use in extreme conditions. However, the connectivity section requires protection from rain or water splashes.

2.2. Mounting

To ensure the product's cooling, maintain a minimum space of 5 cm around the product.

Preferably, mount it on a vertical wall.

Any other mounting method will result in a performance decrease of approximately 10% to 20%.

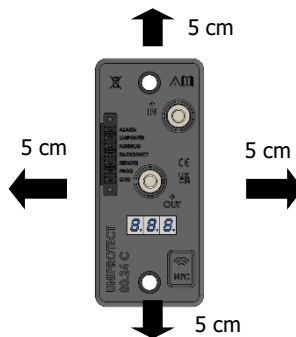

2.3. Precautions

Do not install Uniprotect above the batteries.

Always install the Uniprotect device close to the battery (<50 cm) to avoid voltage drops in the cables.



A voltage drop on an undersized or excessively long cable between the battery pole and Uniprotect can trigger an alarm or an unexpected shutdown.

2.4. Installation instructions



Uniprotect requires a common ground between the battery bank and the load.

A properly rated fuse must be installed between the battery and Uniprotect in compliance with applicable regulations.

The loads/electrical appliances must be installed after the complete programming of the Uniprotect discharge controller.

We recommend using suitable cable cross-sections for the various power connections, and keeping lengths to a minimum.

Advice on minimum cable cross-section:

Current	Cable length < 0,5 m	Terminal diameter	
		UNIPROTECT 80.24 C	UNIPROTECT 160.24 C
< 50 A	16 mm ²	M6 Recommended tightening torque 5 Nm	M8 Recommended tightening torque 9 Nm
50 - 100 A	25 mm ²		
100 - 150 A	35 mm ²	N.a.	
150 - 250 A	50 mm ²		
> 250 A	70 mm ²		

Uniprotect has been designed for current flow from + IN to + OUT ONLY. Reverse current flow from + OUT to + IN is strictly forbidden and will damage the device. Damage not covered by warranty.

If you connect loads with capacitors (e.g., DC-AC inverters), Uniprotect may activate short-circuit protection. However, the UNIPOWER PRO series can be directly connected thanks to its SOFT START feature.

To remotely control another brand of inverter or UNIPOWER, use the "Unipower" terminal on your Uniprotect if compatible.

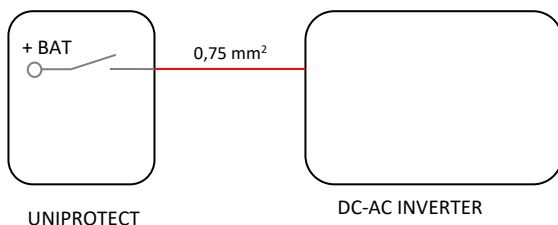

3. CONTROL PANEL

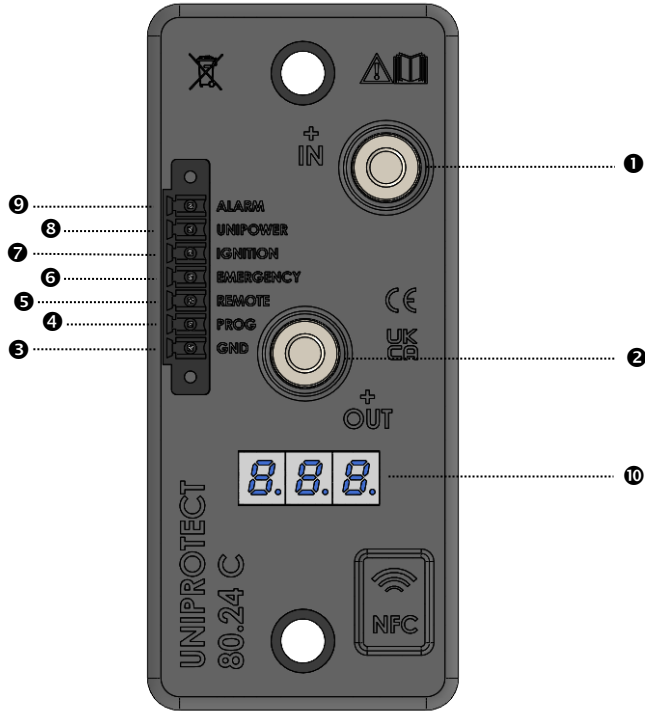

- 1** + IN: Positive battery terminal
Only one cable should be connected
- 2** + OUT: Positive consumer pole.
Only one cable should be connected
- 3** GND: Negative voltage reference. Connect this terminal to the negative pole of the battery using 0.75 to 1.5 mm² wire. Do not connect any other device.
- 4** PROG: Programming pin
- 5** REMOTE: Allows control of the +OUT output via an external switch.
- 6** EMERGENCY: Forces connection of load for 4 minutes if battery voltage is and remains above 8.5V/17V. **No voltage protection when using this mode.**
- 7** IGNITION: Allows vehicle load disconnection based on engine shutdown with pre-programmed time delay
- 8** UNIPOWER: Allows ON/OFF control of AC load via a Unipower PRO.
- 9** ALARM: Possibility of connecting the negative pole of an LED, buzzer or relay.
(Imax: 500 mA, short-circuit protected).
- 10** Programming display: for displaying different modes
- Output Status Display:
- ON output: Flash 1 point every 10 seconds
 - OFF output: Permanently off
 - Under voltage: Flash L dots every 10 seconds
 - Over voltage: Flash H points every 10 seconds
 - Overheating: Flash OH every 10 seconds
 - Short circuit: SC flash every 2 seconds

4. TECHNICAL DATA

	Uniprotect 80.24 C	Uniprotect 160.24 C
SYSTÈM		
Technology	MOS Low Voltage Drop	
Operating voltage	6 to 35V	
Rated current 100% at 60°C	80 A	160 A
Rated current 100% at 40°C	100 A	200 A
On transient current at 60°C	150A - 45 seconds 200A - 20 seconds	300A - 45 seconds 400A - 20 seconds
Peak current (0,2 s)	400 A	800 A
Auto-consommation	Programming mode : 1 to 5 mA / Normal mode : 0,6 mA Low voltage cut-off : 0,2 mA	
Internal temperature sensor	Yes	
BATTERY		
Acceptable battery voltage	12 or 24V	
ALARM		
Delay time	10 s	
Maximum current	500 mA	
SETTINGS		
Modes	Timer / Ignition / Emergency / Unipower	
Disconnection voltage	yes	
Disconnection delay	90 s (adjustable from 20 s to 900s)	
Re-connection voltage	yes	
Re-connection delay	15 s (adjustable from 10 s to 600s)	
MÉCANICAL CARACTÉRISTICS		
Dimensions in mm (LxWxH)	105 x 45 x 25	105 x 55 x 30
Weight	0,250 Kg	0,350 Kg
Connection	M6	M8
Tightening torque	5 Nm	9 Nm
Operating temperature	-25°C > +60°C	
Storage temperature	-40°C > +80°C	
Protection ratings	Electronique IP 67 / Connectique IP 00	

5. CONNECTION DIAGRAMS

The diagrams below are valid for use of your Uniprotect as a low battery voltage protection.

5.1. Connection advice



Do not connect the **+ OUT** output until UNIPROTECT has been fully configured and pre-wired.

- 1 Connect the **+ IN** input from your battery pack.
- 2 **Without connecting the connector**, connect the GND terminal of the connector to the system's common ground.
- 3 Connect the connector to the UNIPROTECT. Your UNIPROTECT starts up. The display shows the software version of the product.
- 4 Use PROG mode (see page 13) to set the desired settings.
- 5 Disconnect the connector and wire the various inputs/outputs.
- 6 Connect the consumers to the **+OUT** output.
- 7 Reconnect the connector. Your UNIPROTECT will start, and the +OUT output will be connected at the end of the product's startup process

5.2. Complete diagram

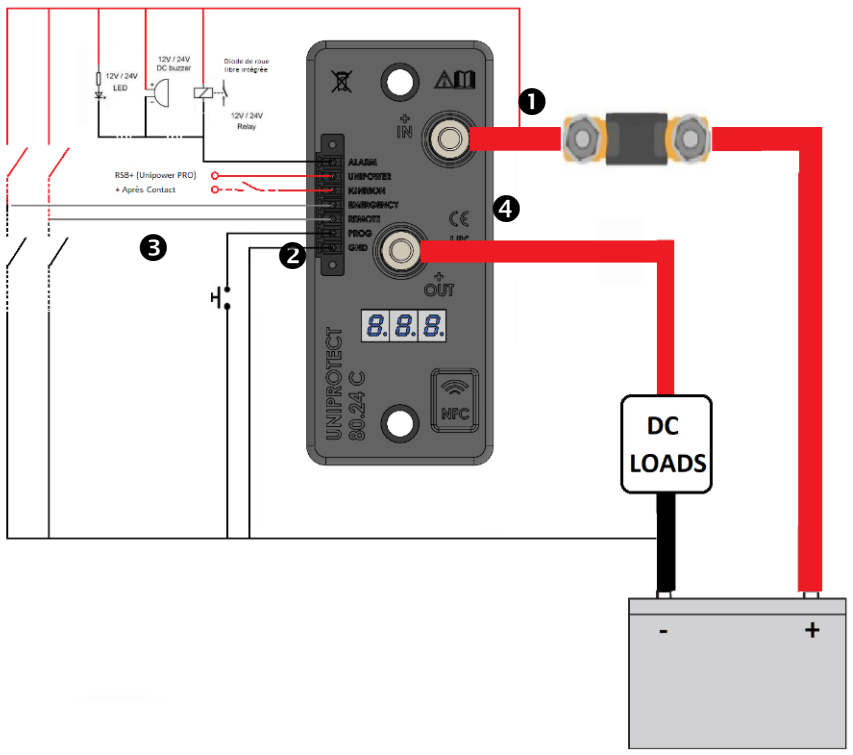

5.3. Diagram with remote control (REMOTE)

The REMOTE input terminal allows manual control of the state of the +OUT output of your Uniprotect, if the voltage permits. It is recommended to use a toggle switch or equivalent, or a relay contact. The operation of this input can be adjusted using the parameter r xx.

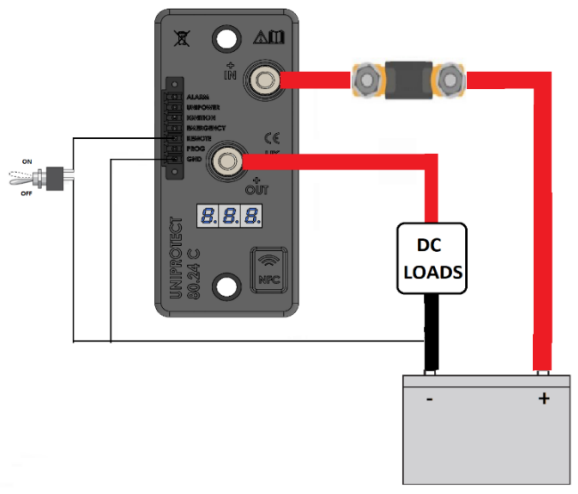

5.4. Diagram with DC-AC inverter control (UNIPOWER)

In the event of low-voltage protection, the Unipower terminal enables your DC-AC inverter to be controlled at the same time as the +OUT output, or with a slight delay (adjustable via parameter U xx).

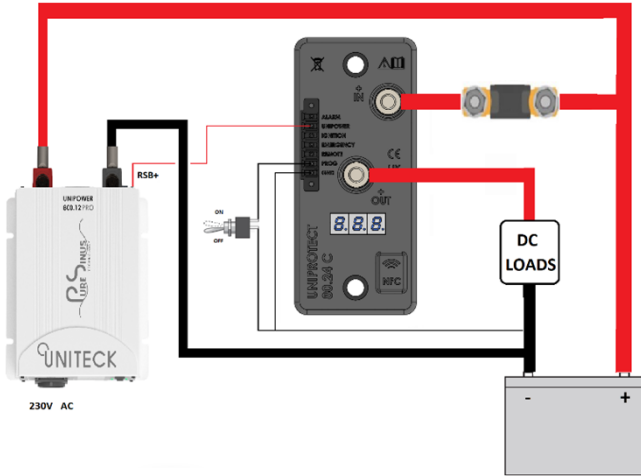

5.5. Wiring diagram for an alarm unit

Uniprotect allows you to connect the negative pole of an LED, buzzer or relay to 12 or 24V DC.

Maximum current I_{max} is 500 mA. This output is protected against short-circuits.

It is possible to adjust the configuration of this output using the A xx parameter.

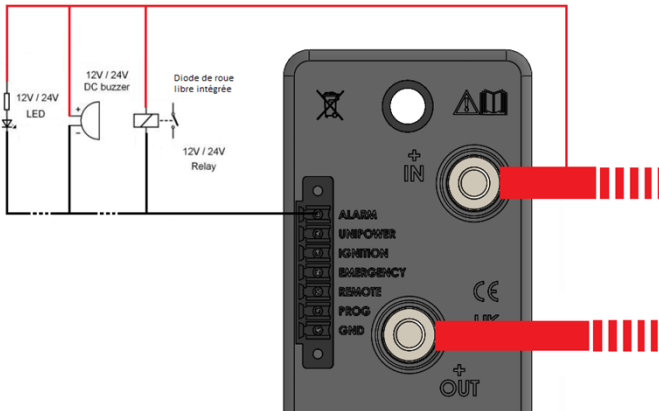

5.6. Diagram with several Uniprotect protection units

Depending on your usage, DC or AC loads may vary in importance. To prioritize the shutdown of loads, it is recommended to use multiple Uniprotect devices with different shutdown and restart parameters. In this case, you will need to set the P x parameter differently for each device.

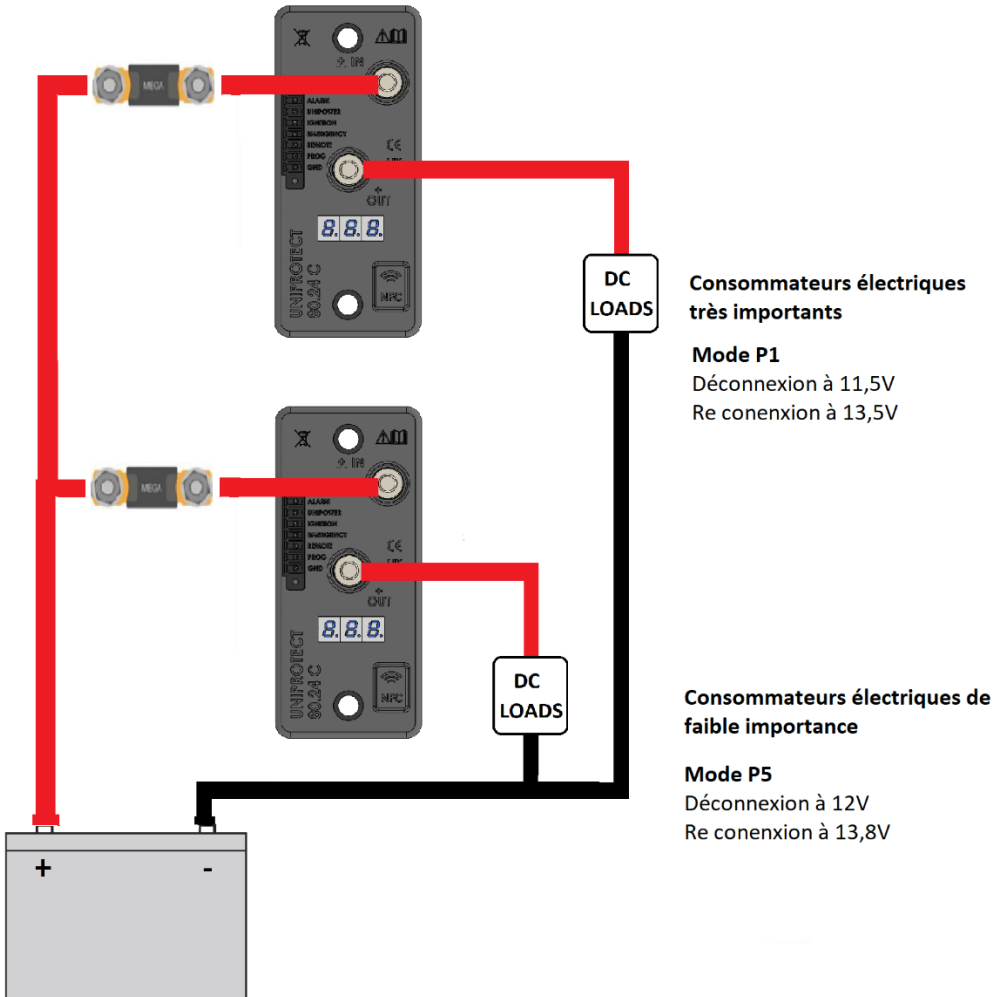

5.7. Diagram using the IGNITION terminal

When Uniprotect is used in a vehicle, it allows disconnection of the loads after the engine stops, with a preprogrammed delay ranging from 30 minutes to 72 hours, thanks to the "+ After ignition" terminal. In this mode, low voltage protection is active. It is possible to adjust the configuration of this output using the I xx parameter.

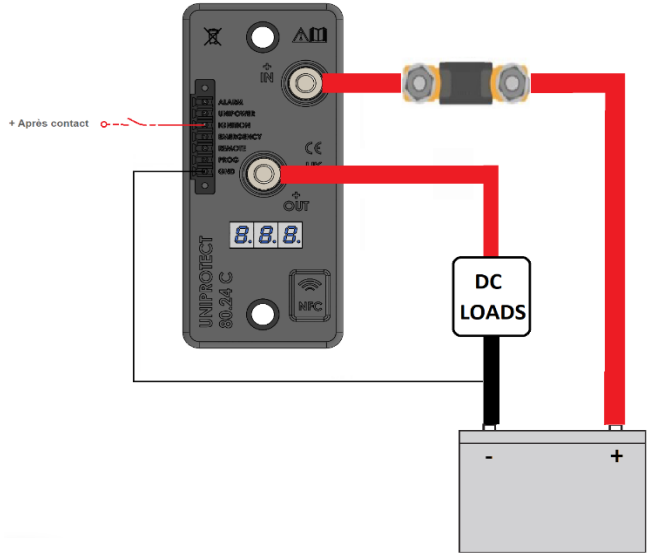

5.8. Diagram using EMERGENCY terminal

Uniprotect has an EMERGENCY input that allows the +OUT output to be controlled by overriding low voltage protection and alarms **for 4 minutes** if the battery voltage is above 8.5V for 12V systems and 17V for 24V systems.

This mode is used to connect loads/electrical appliances in cases of extreme emergency, even if the battery voltage indicates a very low state.

This input reacts to either a positive or negative voltage level, depending on the adjustable setting E xx.

When the EMERGENCY mode is activated, the display "Ery." intermittently.

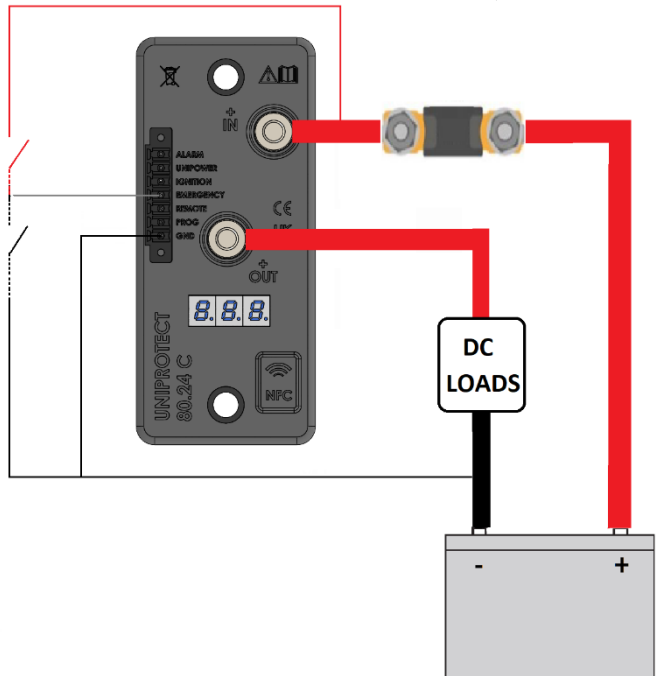

6. PROGRAMMATING



Before entering Programming mode, always disconnect the OUT output.

6.1. Choice of programming

To enter programming mode, temporarily connect the PROG terminal to the negative terminal of your system using the provided programming wire.

- Between **5 and 10 seconds**: the display flashes "Pr" to indicate that you are entering **Simplified Programming mode**. Release the Ground connection to enter this mode.
Once in Simplified Programming mode, if no action is taken within 10 seconds, Uniprotect will exit programming mode.
- Between 10 and 15 seconds: the display flashes "PrA" to indicate that you are entering **Advanced Programming mode**. Release the ground connection to enter this mode.
Once in Advanced Programming mode, select END display for at least 5 seconds to exit programming mode.

-BAT



6.2. Simplified programming

When the display shows "Pr", you can scroll through the various programming category by making a short connection between the PROG terminal and the negative pole.

To modify a setting, display the setting to be adjusted (e.g. Axx alarm), connect **and hold** the PROG terminal to the negative pole.

The display begins to scroll through the various setting values by programming category, according to the tables below. To confirm a setting, remove the PROG terminal from the negative pole. The current setting will then be validated. Make a short connection between the PROG terminal and the negative pole to move on to the next setting. Proceed in this way for the various settings.

Changing a setting within a program category will not affect other program in the groups.

Once all settings are finalized, the final validation occurs after 10 seconds. The product then becomes operational. Uniprotect will shut down if the battery voltage permits.

Program group	Values (*Default settings)
Setting disconnection and reconnection voltage	<p>P0 : Mode Safe - - 11,0V / 13,8V</p> <p>P1 : Mode Safe - 11,5V / 13,5V</p> <p>P2* : Mode Safe 12,0V / 13,0V</p> <p>P3 : Mode Safe + 12,0V / 13,5V</p> <p>P4 : Mode Safe ++ 12,0V / 13,8V</p> <p>Usr : Using Advanced Programming. Enter Advanced Programming mode to observe Voltage and Time settings.</p>

Program groups	Values (*Default settings)
Alarm output settings	<p>A 0*: This function is disabled. Alarms are not controlled, and no alarm history will be available.</p> <p>A 1 – LED/Buzzer Mode</p> <ul style="list-style-type: none"> - Low connection voltage reached: The ALARM output is activated by intermittently 10 seconds after the voltage drops below the disconnection threshold. Load/ electrical appliances are disconnected 90 seconds later (adjustable disconnection delay), and the alarm stops. The alarm will also stop if the voltage rises above the disconnection threshold before the disconnection delay ends. The load will be reconnected if the battery voltage rises above the reconnection threshold within 15 seconds (adjustable reconnection delay) - Overvoltage (15.5 or 31V) adjustable from 15 to 16V / 30 to 32V: Loads are deactivated without delay. ALARM output activated by pulse. Load are reconnected and the alarm is stopped when the voltage has fallen by 0.2V/0.4V relative to the setting, without delay. <p>A 2 – LED/Buzzer Mode</p> <ul style="list-style-type: none"> - Low disconnect voltage reached: The ALARM output activates the alarm by intermittently, 10 seconds after the voltage has fallen below the disconnection threshold. Loads/electrical appliances are not disconnected. The alarm stops if the voltage rises above the disconnection threshold. - Overvoltage (>15.5V or 31V) adjustable between 15 to 16V / 30 to 32V: The ALARM output is activated by a pulse. Load/ electrical appliances are reconnected, and the alarm stops when the voltage has dropped by 0.2V / 0.4V below the set value, without delay. <p>A 3 – Indicator mode/Buzzer</p> <ul style="list-style-type: none"> - Low disconnect voltage reached: The ALARM output is activated by intermittently, 10 seconds after the voltage has fallen below the disconnection threshold. Load/electrical appliances are disconnected for 90 seconds, and the alarm goes off. CAUTION: Unlike A1 mode, once the alarm has been triggered, it can only be switched off by switching to protection. If the battery voltage rises between alarm activation and the end of the disconnection delay, the ALARM remains active. The load will be reconnected if the battery voltage rises above the reconnection threshold within 15 seconds (reconnection delay adjustable). The alarm stops at this point. - Overvoltage (>15,5V ou 31V) adjustable from 15 to 16V / 30 to 32V: load deactivated without delay. The relay is activated continuously. Load are reconnected and the relay opens when the voltage has fallen by 0.2V/0.4V relative to the setting, without delay. <p>A4 – Indicator mode/Buzzer /Relay</p> <p>The ALARM output indicates the status of the +OUT output. It is continuously activated if the loads/ electrical appliances are switched off.</p> <p>A5 – Indicator mode/Buzzer /Relay</p> <p>The ALARM output indicates the status of the +OUT output. It is continuously activated if the load/ electrical appliances are switched on.</p>

<p>Alarm output settings (Continued)</p>	<p>A 6 – Relay Mode</p> <ul style="list-style-type: none"> - Low Disconnection Voltage Reached: The ALARM output activates continuously 10 seconds after the voltage drops below the disconnection threshold. Loads will be disconnected 90 seconds later (adjustable disconnection delay), and the alarm stops. The alarm also stops if the voltage returns above the disconnection threshold before the end of the disconnection delay. The load will be reconnected if the battery voltage rises above the reconnection threshold within 15 seconds (adjustable reconnection delay). - Overvoltage (>15.5 or 31V): Adjustable from 15 to 16V / 30 to 32V. Loads/electrical appliances are deactivated without delay. The ALARM output is activated by a pulse. Loads are reconnected, and the alarm stops when the voltage drops by 0.2V/0.4V below the set value, without delay. <p>A 7 – Relay Mode</p> <ul style="list-style-type: none"> - Low disconnect voltage reached: The ALARM output activates a continuous alarm, 10 seconds after the voltage has fallen below the disconnection threshold. Loads/electrical appliances are not disconnected. The alarm stops if the voltage rises above the disconnection threshold. - Overvoltage (>15,5 or 31V) adjustable from 15 to 16V / 30 to 32V: ALARM output is activated by pulse. Reconnection of loads/electrical appliances and shutdown of alarm when voltage drops by 0.2V/0.4V relative to setting, without delay. <p>A 8 – Relay Mode</p> <p>Low Disconnection Voltage Reached: The ALARM output is activated continuously 10 seconds after the voltage drops below the disconnection threshold. Consumers will be disconnected for 90 seconds, and the alarm will turn off.</p> <p>CAUTION: Unlike A1 mode, once the alarm has been activated, it can only be switched off by switching to protection.</p> <p>If the battery voltage rises between alarm activation and the end of the disconnection delay, the ALARM remains active.</p> <p>The load will be reconnected if the battery voltage rises above the reconnection threshold within 15 seconds (reconnection delay adjustable). The alarm stops at this point.</p>
----------------------------------------------	------------------------------------------------------------------------------------------------------------------------------------------------------------------------------------------------------------------------------------------------------------------------------------------------------------------------------------------------------------------------------------------------------------------------------------------------------------------------------------------------------------------------------------------------------------------------------------------------------------------------------------------------------------------------------------------------------------------------------------------------------------------------------------------------------------------------------------------------------------------------------------------------------------------------------------------------------------------------------------------------------------------------------------------------------------------------------------------------------------------------------------------------------------------------------------------------------------------------------------------------------------------------------------------------------------------------------------------------------------------------------------------------------------------------------------------------------------------------------------------------------------------------------------------------------------------------------------------------------------------------------------------------------------------------------------------------------------------------------------------------------------------------------------------------------------------------------------------------------------------------------------------------------------------------------------------------------------------------------------------------------------------------------------------------------------------------------------------------------------------------------------------------------------------------------------------------------------------------------------------------------------------------------------------------------------------------------

<p>control via external terminals</p>	<p>r 0*: This mode is disabled. The REMOTE terminal is inactive. The product does not take into account the state of this input</p> <p>r 1 : UNIPROTECT output closes after activation of this output connected to the positive battery terminal. UNIPROTECT will immediately disconnect the load when this output is deactivated. We recommend the use of a push-button.</p> <p>r 2 : UNIPROTECT output closes after activation of this output connected to the negative battery terminal. UNIPROTECT will immediately disconnect the load when this output is deactivated. We recommend the use of a push-button.</p> <p>IGNITION</p> <p>I -0 * : This mode is disabled. The IGNITION terminal is inactive. The product ignores the state of this input.</p> <p>I xx: This mode allows the disconnection of vehicle load after the engine has stopped with a pre-programmed delay mentioned below. It also protects the battery against low voltages. In this mode, the IGNITION terminal must be used for connecting the vehicle's "+ after contact."</p> <p>The loads/electrical appliances are connected only if the vehicle is started (+APC present) or during the time delay.</p> <p>I05 : 30 min / I-1 : 1h / / I-5 : 5h / I-6 : 6h / I12 : 12h / I18 : 18h I48 : 48h / I72 : 72h</p> <p>EMERGENCY</p> <p>E 0*: This mode is disabled. The EMERGENCY terminal is inactive. The product ignores the state of this input.</p> <p>E 1 : The UNIPROTECT output closes for 4 minutes if this output is connected to the positive battery terminal by a pulse, and if the battery voltage is greater than 8.5V/17V. We recommend the use of a push-button. The display flashes ErY. Low-voltage protection and alarms are deactivated for the duration of the operation.</p> <p>E 2 : UNIPROTECT output closes for 4 minutes if connected to the negative battery terminal by a pulse, and if the battery voltage exceeds 8.5V/17V. We recommend the use of a push-button. The display flashes ErY. Low-voltage protection and alarms are deactivated for the duration of the operation.</p>
<p>Powering Off a Inverter</p>	<p>UNIPOWER</p> <p>U 00*: The Unipower terminal switches off your inverter at the same time as the +OUT output. It switches on your inverter when the + OUT output becomes active.</p> <p>U 20 : The Unipower terminal stops your inverter 0.2V before disconnection voltage.</p> <p>U 30 : The Unipower terminal stops your inverter 0.3V before disconnection voltage.</p> <p>U 40 : The Unipower terminal stops your inverter 0.4V before disconnection voltage.</p> <p>U 21 : The Unipower terminal stops your inverter 0.2V after the disconnection voltage.</p> <p>U 31 : The Unipower terminal stops your inverter 0.3V after the disconnection voltage.</p> <p>U 41 : The Unipower terminal stops your inverter 0.4V after the disconnection voltage.</p> <p>Re-connection occurs at the same time as +OUT re-connection.</p>

6.3. Advanced programming

To enter programming mode, using the provided programming wire, temporarily connect the PROG terminal to the negative pole of your system.

Between **10 and 15 seconds**: The display flashes "PrA" to indicate that you are entering **Advanced Programming mode**. Release the connection.

PrA flashes slowly.

Reconnect the PROG terminal to the ground. At this point, Ud (Disconnection Voltage) is displayed. To scroll through the setting, connect the PROG terminal to the ground for 1 second. The settings Ud / Ur / Td / Tr / Uov / End scroll with each connection.

To set a configuration, go to the setting, wait 3s, the value is displayed.

From now on, each connection to ground will modify the value. When you've chosen your setting, wait 3 sec. The value flashes and the display returns to Ud / Ur / Td / Tr / Uov.

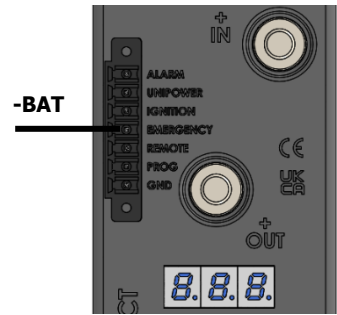

In Advanced mode, modes P0 to P5 are no longer used. User mode USr is activated.

Once in Advanced Programming mode, select the End display for at least 5 seconds to exit programming mode.

Advanced Programming group	Values
Setting disconnection and reconnection voltage	<p>Ud - Disconnection voltage: de 9,3 to12,3V / 18,6 to 24,6V</p> <p>Ur - Reconnection voltage: Ud + 0,1V to 13,8V / Ud + 0,2V to 27,6V</p> <p>Ur is always at least 0.1V higher than Ud.</p> <p>Td - Disconnection delay: from 20 seconds to 900 seconds</p> <p>Tr - Reconnection delay: from 10 seconds to 600 seconds</p> <p>Uov - Overvoltage protection voltage: from 15,0 to 16,0V</p>

6.4. Factory setting

Below is a summary of the factory settings.

This setting can be reprogrammed by connecting the **PROG terminal for 20 seconds** to the **negative terminal** of your battery. The display will show CAL for a very short time.

Values								
Disconnection and reconnection voltage	Alarm	Remote control			Inverter control	Switch-off delay	Re-connection delay	On voltage
P2	A0	r0	I-0	E0	U00	90 sec	15 sec	15,5V

7. HISTORY VIA UNIAPP

Uniprotect records daily data on maximum voltage, minimum average voltage, the number of alarms, the number of protections activated, and the duration of the +OUT output in protection mode.

Uniprotect has a history equivalent to the last 500 days since it was connected to your battery.

Note, It is possible to retrieve the history using UNIAPP even if your UNIPROTECT is no longer connected to the battery.

Your battery must be connected for at least 24 hours to start generating the HISTORY graph.



On your smartphone, make sure the **NFC** function is active.

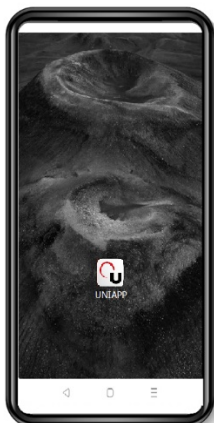

Open the Uniapp application on your smartphone.
The "UNITECK - UNIAPP" application is available for free download from Apple Store or Playstore.



Select UNIPROTECT product family



Scan your product where indicated.

As the position of the NFC scanner varies from one SMARTPHONE to another, it may take some time to move the smartphone gently around the NFC mark on your Uniprotect.

Try again several times if necessary.



History building in progress.

Wait at least 24 hours.

During this time, you can still view the configuration of your UNIPROTECT



Example of history display.

The last day displayed is D-1. Navigate the graph using the Right or Left arrows, or the calendar.



On the graph page, you can view product information and settings by clicking on the **Info** icon in the top right-hand corner.



On the graph page, you can **download the history** in Exel .CSV format for use or for sending to a third party via a messaging service.

Uniprotect can also be used to control an electronic battery charger, notably by stopping and/or protecting the charger in the event of overvoltage.

Below is the wiring diagram for controlling the charger via the REMOTE terminal. The charger is also protected against overvoltage at the battery terminals.

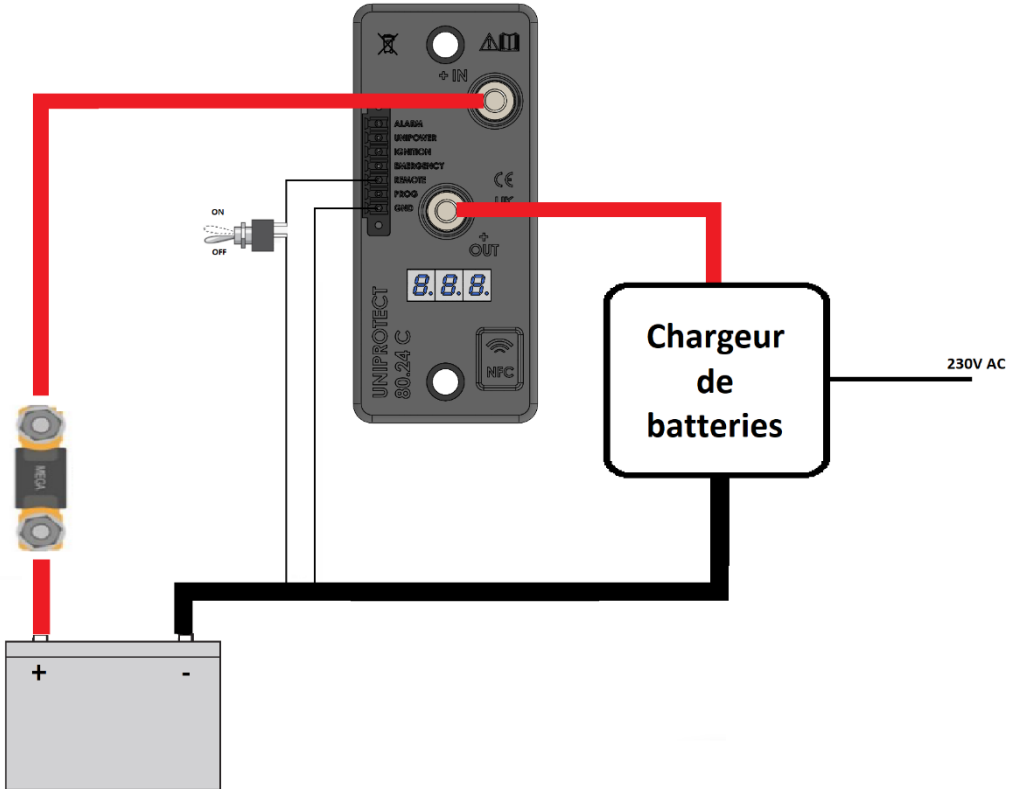

Depending on your use, you may need to control the discharge as well as the charge of your battery. It's possible to switch off DC loads and order a charger with 2 Uniprotects.

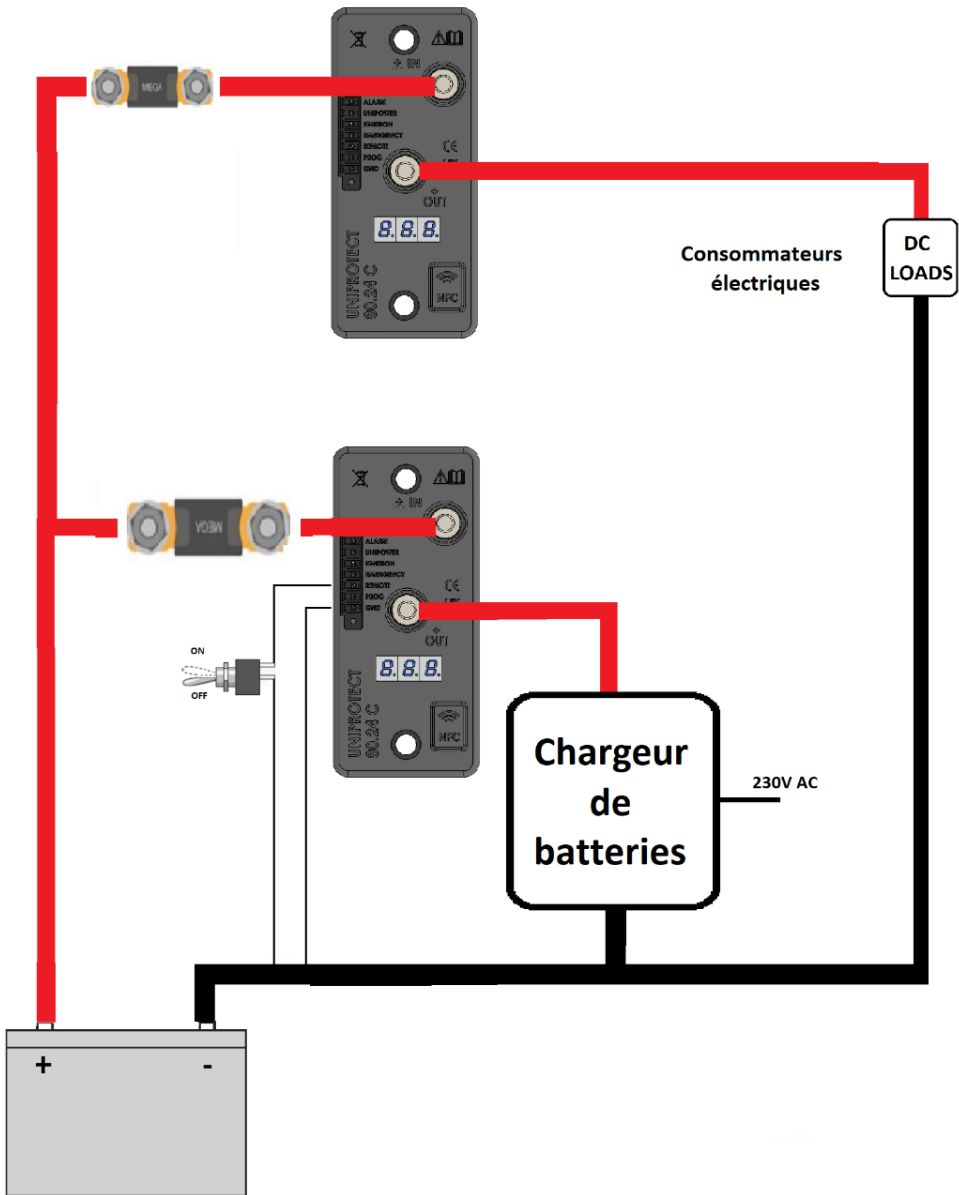

9. APPENDICES

9.1. Pictograms

	Device complies with European directives		Product subject to selective collection - Do not dispose of in domestic waste.
	Warning! Read instruction manual before use.		Device complies with UK requirements.

9.2. Warning

- Follow the battery manufacturer's safety instructions. If in doubt, consult your dealer or installer.
- Batteries may produce flammable gas. Avoid all flames and sparks.
- When handling the battery (except gel), there is a risk of acid spillage, protect yourself.
- Never short-circuit the + and - of the battery or cables: risk of explosion or fire.
- Maintenance : check wiring and connections at least once a year.
- All work must be carried out in accordance with local electrical regulations.
- The equipment used in your installation, such as connectors, cables, fuses, disconnectors, etc., must be suitable and comply with the laws and regulations in force in the country for the intended application.
- This equipment is not intended for use by persons (including children) with reduced physical, sensory or mental capabilities, or by persons lacking experience or knowledge, unless they have been given supervision or instruction concerning use of the equipment by a person responsible for their safety.
- Children should be supervised to ensure that they do not play with the device.

9.3. Defects, causes, solutions

Below, you will find the table of error codes displayed on the product. The error codes are displayed in a flashing manner to limit consumption. The display of errors will stop after 10 minutes to limit consumption.

Indicator code	Causes	Solutions
Flashes H every 10 s	Overvoltage	Disconnect charging elements and check. Poor battery voltage. verify your system.
Flashes SC every les 2 s	Short circuit detected	Verify your wiring. Disconnect loads/electrical appliances not suitable for the product (e.g. inverter).
Flashes OH every 10 s	Overheating	Disconnect some or all load. Reduce consumption. Check that the product's natural ventilation is not obstructed.
Flashes L every 10 s	Under voltage	Your battery has dropped below 8.5V. The indicator will stop when the battery voltage rises above the 10V threshold. Wrong choice of battery voltage. Select the correct voltage mode.

9.4. Warranty

The warranty covers any manufacturing defect or fault for 2 years from the date of purchase (parts and labor).

The warranty does not cover normal wear and tear of parts (e.g. cables, etc.), battery voltage errors, incidents due to misuse, dropping, dismantling or any other damage due to transport.

In the event of a breakdown, return the unit to your distributor, enclosing:

- dated proof of purchase (receipt, invoice, etc.)
- the after-sales service return form available on our website

If necessary, you can contact our after-sales service at sav@uniteck.fr.