

Manual for *E40i* Electric self-tailing winch



Contents

| | | |
|-----|---|----|
| 1 | Introduction..... | 3 |
| 2 | E40i electric winch..... | 5 |
| 2.1 | Included parts..... | 5 |
| 2.2 | Optional parts..... | 6 |
| 2.3 | Technical specification..... | 7 |
| 3 | Installation..... | 9 |
| 3.1 | Installation preparation..... | 9 |
| 3.2 | Winch installation..... | 10 |
| 3.3 | Adjusting the Self-tailing arm..... | 14 |
| 3.4 | Control button installation and configuration..... | 14 |
| 4 | Operation..... | 15 |
| 4.1 | Normal operation..... | 15 |
| 4.2 | Pairing with an electric furling mast as outhaul-winch..... | 16 |
| 4.3 | Emergency situations..... | 17 |
| 5 | Trouble shooting..... | 17 |
| 6 | Service and maintenance..... | 18 |
| 6.1 | Frequent maintenance..... | 18 |
| 6.2 | Extended Maintenance..... | 21 |
| 6.3 | Professional Maintenance..... | 22 |
| 7 | Spare parts..... | 24 |
| 8 | Disposal..... | 25 |
| 9 | Warranty..... | 26 |

1. Introduction

Congratulations on the purchase of your Seldén E40i electric winch. The purpose of this winch is to simplify activities like hoisting a sail or tensioning an outhaul, a reef line or any other line used for sail trim. The most common location of the E40i winch is the coach roof right behind the line stoppers. As the electric motor and the gear box are located inside the drum, no part except for the cables is protruding the deck. You will have clear head room down below and no large cut outs in the deck.

This manual cover installation and operating instructions for E40i electric winch. The model designation is found on the top of the winch. Serial number is found on the delivery box and on the winch base, as shown below.

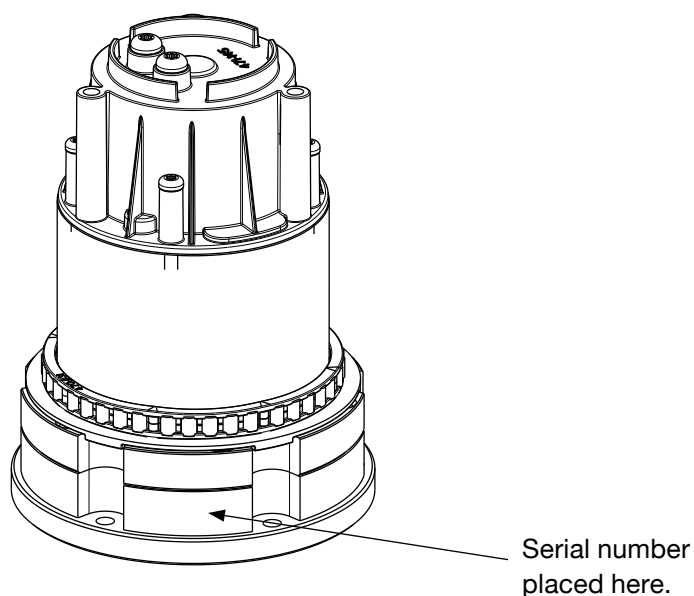

Please read the entire manual before assembly/usage and keep the manual available for future reference.

Safety Precautions

Carefully pay attention to, and follow, instructions with the following symbols:



This symbol indicates a critical moment in the assembly or critical technical advice.



This symbol indicates a potentially hazardous situation. If not avoided, this could result in serious personal injury or damage to property.

Choosing the correct version of Halyard winch for your boat:

The key to a safe and properly working installation is correct dimensioning in relation to the boat size the product(s) shall be used on. Seldén provides dimensioning guidelines in catalogues, leaflets and on the website. If there are any questions about selecting the right product, please consult an authorized Seldén dealer. All dealers are listed at www.seldenmast.com and divided into categories describing their competence.



The E40i electric winch is designed for line handling while sailing and is primarily intended for halyard and outhaul applications.. Mooring, towing or any type of misuse may lead to winch failure and/or serious or fatal injuries.



Exceeding the stated safe working load may lead to winch failure and/or serious or fatal injuries.



Keep hands, fingers, hair and clothing away from moving parts while winch is in use. It is recommended to let only one person work with the winch at any time.



Turn off the power to the Power supply and SEL-Bus system when not in use, to decrease the risk of unintentional activation.





Control buttons should be placed near the winch or in such a way that the operator has complete control over the course of events.

2 E40i electric winch

2.1 Included parts

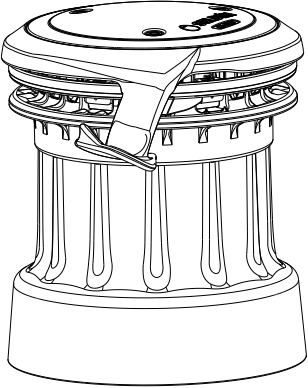
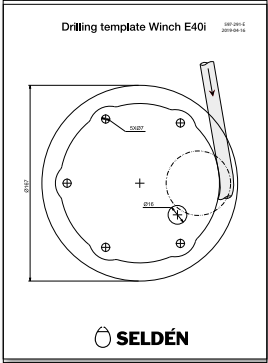
The following parts are included in your E40i electric winch package:

| | |
|---|--|
| <p>471-540-03 471-540-04</p> <p>E40i Electric winch</p> |  |
| <p>597-291-E</p> <p>Drilling template</p> |  |
| <p>597-445-E</p> <p>Manual E40i Electric winch</p> |  |

2.2 Optional parts

Following parts can be purchased as extras together with your E40i electric winch package:

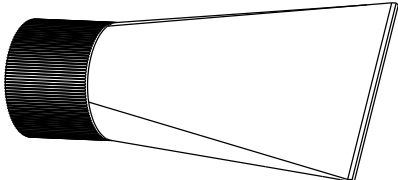
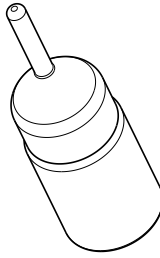
| Art. No | |
|--------------------------------------|--|
| 312-501 Seldén lubrication grease |  A technical line drawing of a tube of lubrication grease. The tube is tapered, wider at the top and narrower at the bottom. The top end is capped with a dark, textured material, possibly a cap or a seal. |
| 312-709-01 Seldén pawl oil |  A technical line drawing of a small bottle of oil. The bottle is cylindrical with a slightly wider base. It has a small, thin tube or nozzle protruding from the top center. |

2.3 Technical specification

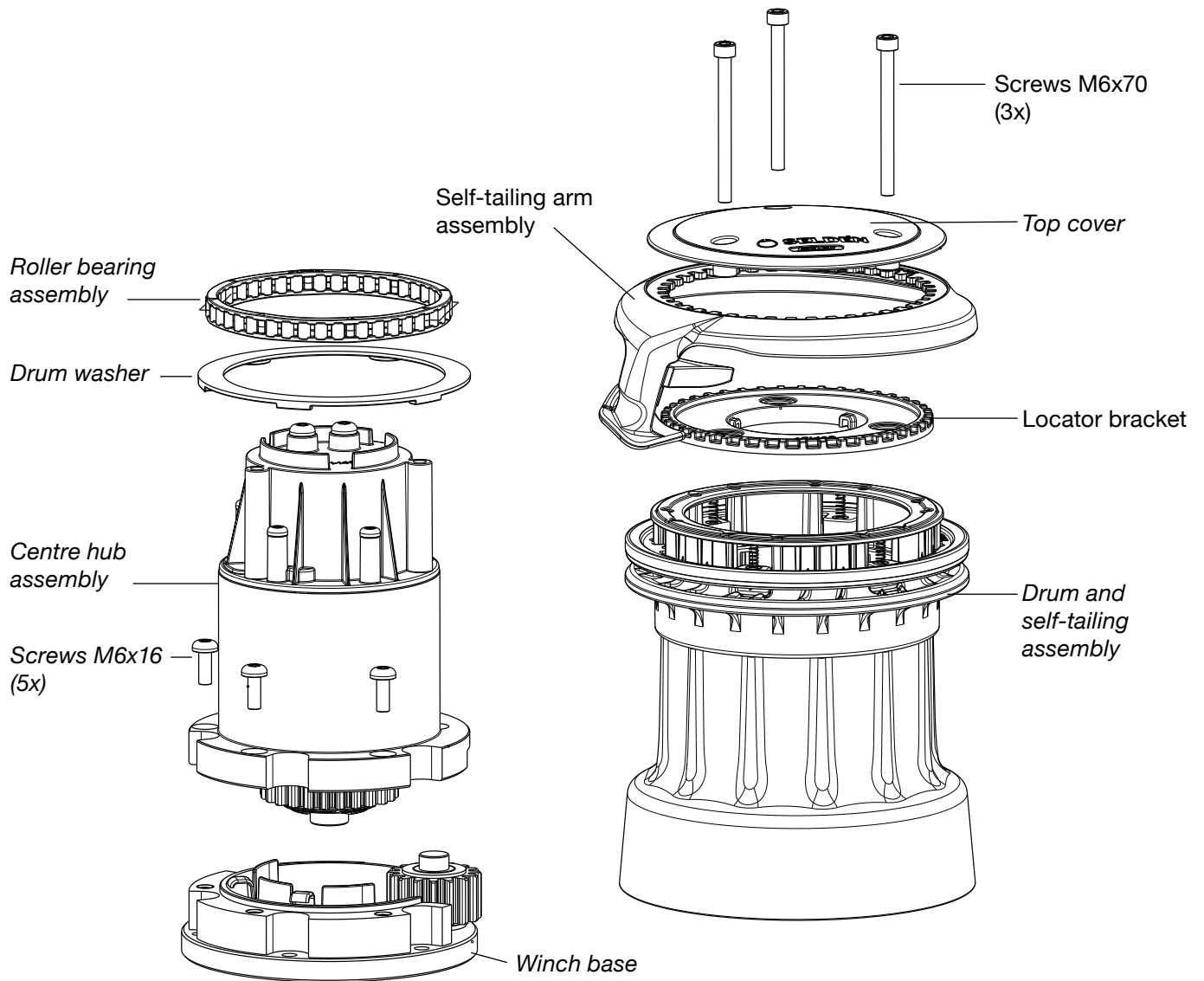

Dimensions and technical data

| Item. No. | Base diameter (ØB) [mm] | Drum diameter (ØD) [mm] | Height (H) [mm] | Weight [kg] | Suitable Line dimensions [mm] | Safe Working Load (SWL) [kN] | Power consumption (W) | Line-speed 1 [m/min] | Line speed 2 [m/min] | Line speed 3 [m/min] | Electric cut off load (ECL) [kN] |
|------------|-------------------------|-------------------------|-----------------|-------------|-------------------------------|------------------------------|-----------------------|----------------------|----------------------|----------------------|----------------------------------|
| 471-540-10 | 167 | 123 | 198 | 9,1 | 8-14 | 11,2 | 1200 | 6,5 | 11 | 17 | 6 |
| 471-540-20 | | | | 6,8 | | | | | | | |

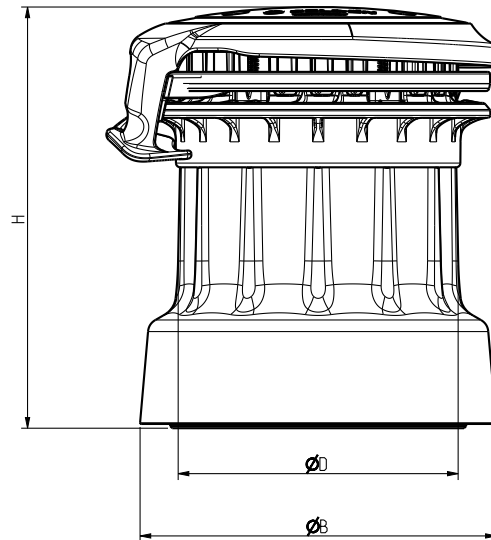

Exceeding the stated safe working load may lead to winch failure and/or fatal injuries.

Power supply and SEL-Bus system

The electric winch is connected to the E40i motor control unit, MCU, as a part of the Seldén Power Supply and SEL-Bus system. All power supply and SEL-Bus system parts are sold separately. Parts and packages are described in Seldén Power Supply and SEL-Bus system: Order guide 597-283-E.

The illustration below shows an example of E40i basic network installation. The complete Power Supply and SEL-Bus system of each customer will vary and can include additional units and functions (e.g. furlex electric and synchronized main furling).

1. Battery
2. Main switch/fuse
3. Power supply unit (PSU)
4. E40i Electric winch
5. Push buttons for E40i
6. SEL-Bus backbone cables and connections
7. Motor control Unit Winch

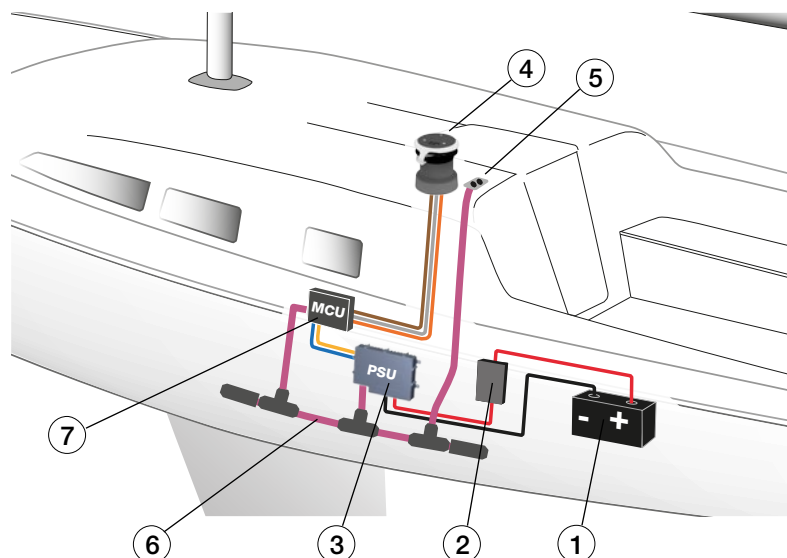

3 Installation



Installation of a Seldén Winch must be carried out by a competent installer who has read and understood this installation manual, the purpose and function of the winch and has checked the loads, winch sizing and mounting requirements prior to installation.

Winch orientation, position relative to associated components and location regarding deck reinforcement and suitability must be checked and any reinforcement work carried out prior to installation. The installer takes full responsibility to ensure these checks have been undertaken. This may require the assistance of a boat yard or marine engineers.

Seldén Mast does not provide fasteners. The installer is responsible for the sourcing and specifying load capacity of the fasteners, ensuring they are rated for the expected loads from the winch. Any fastener should be made from marine grade stainless steel.

Seldén Mast does not take responsibility for incorrect installation of a winch, insufficient reinforcement of the deck at the location of the winch, water ingress due to insufficient sealing or any damage to interior as a result of water ingress.

3.1 Installation preparation



Before proceeding with any installation, read chapter **4.3 Emergency situations**. This chapter highlights important considerations regarding the placement of the E40i electric winch with regards to other winches on the yacht. In the following recommendations and instructions, it is assumed the information in chapter **4.3** has been taken into consideration.

Power supply and SEL-bus system

Before installing the winch, consider the information given in installation manual 597-275-E and make sure any instructions regarding installation of the power supply and SEL-bus system is followed when progressing with the installation of the E40i electric winch.

To ensure the correct power supply to the winch, the E40i winch must be paired and connected to a Seldén MCU (Motor Control Unit) labelled for winch use. Failing to do this or using any other means of power supply will void the warranty and may lead to damages to the boat and/or equipment or potentially fatal injuries.

Orienting the winch

The E40i electric winch is primarily intended for line handling on sailboats such as halyards and outhaul. It is not recommended to use the winch for any other purpose than intended.

For optimum performance during use, the winch must be oriented so that the line enters the drum tangential to the drive gear as shown in the picture below.

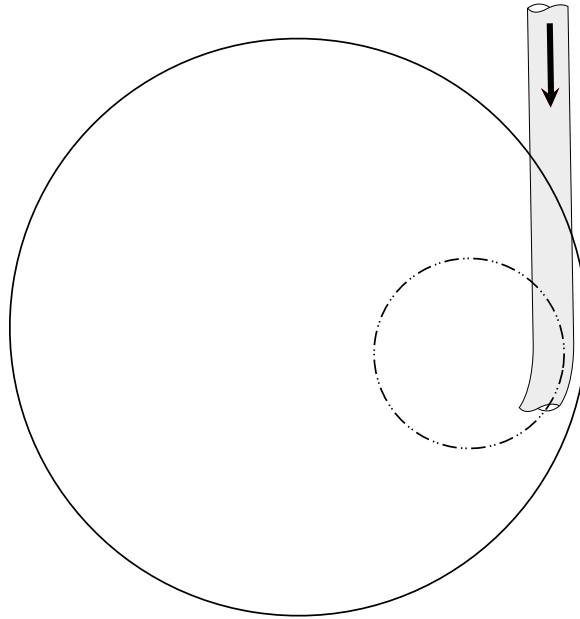

Failing to align the winch in accordance with the figure above may lead to winch failure which may lead to fatal injuries or damages to the boat or equipment.

3.2 Winch installation

The winch can either be installed with screws secured with nuts below deck or with screws fitted directly in the deck, provided that the deck is prepared with appropriate reinforcement plates.

Follow procedure A or B depending on your installation method:

A: Installation through deck with screws and nuts below deck

B: Installation directly into the deck



Installing the winch directly into the deck is only possible on yachts equipped with aluminium- or stainless-steel deck-inserts intended for mounting winches. If at any point there is uncertainty whether the yacht is equipped in this way, please abort the installation and seek assistance at the yard or builder.

Installation procedure

1. A/B:

Dismantle the winch according to chapter 6.1, steps 1-3.

2.

A/B:

Cut out the drilling template provided in the delivery box.



3.

A/B:

Test-fit and align the drilling template in accordance with chapter 3.1 *Orienting the winch* and attach it to the deck using masking tape.

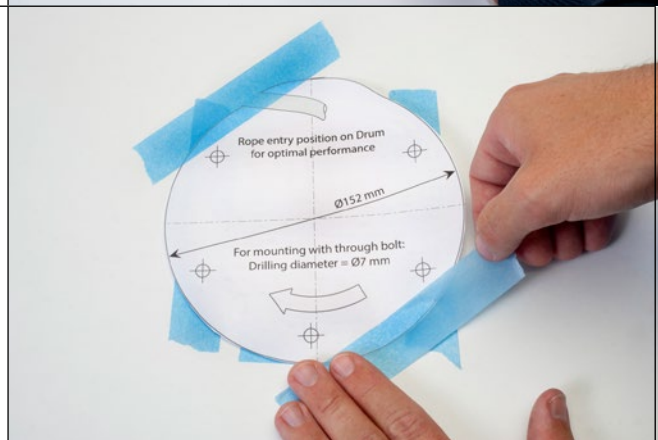

4.

A/B:

Mark all hole positions using an awl or center-punch.

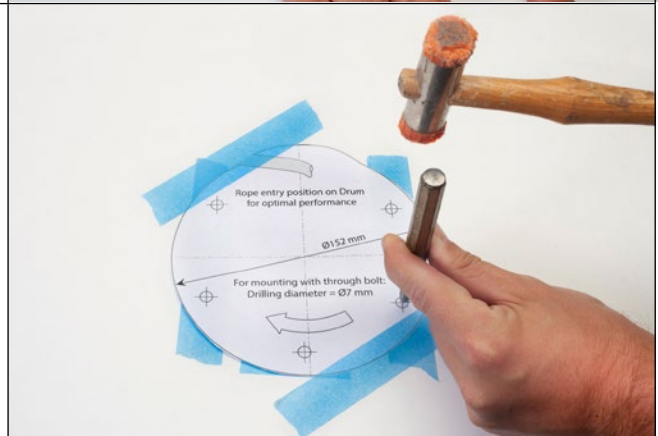

5.

A/B:

Remove the template and pre-drill a pilot hole at each position using the 4mm drill bit.



6.

A:

Continue drilling the holes to final size, using the Ø7mm drill bit.

B:

Continue drilling the holes to the final size, using the Ø5mm drill bit. Clean the hole followed by tapping a thread to M6X1.

7.

A/B:

Finish the feeding hole for the electric motor cables by sizing the hole to Ø14-Ø20 mm by either drill or hole-saw.

8.

A/B:

Countersink each hole approximately 3 mm deep, to allow enough marine sealing compound to be applied to stop water ingress (not needed for the cable feeding-hole).



9.

A/B:

Remove any masking tape and debris, then proceed to wipe the area down using acetone or methylated spirits to remove any grease.



10.

A/B:

Fill the countersunk holes with marine sealing compound as well as putting compound around the cable feeding hole.

While feeding the cables through the feeding hole, mount the winch, ensuring it is correctly aligned and that no cable is pinched between the winch base and the deck.



11.

A:

Fit the screws and tighten the winch down to the deck in a crosswise pattern



Recommended tightening torques for screws are as follows:
M6 = 7 Nm

B:

Apply thread locking adhesive to screws intended for mounting the winch.
Fit the screws and tighten the winch down to the deck in a crosswise pattern.



Recommended tightening torques for screws are as follows:
M6 = 7 Nm



Avoid mixing locking adhesive and marine sealant as this may cause either to fail.

12.

A/B:

Reassemble the winch.

13.

A/B:

Crimp a suitable connector to each cable end and fit the cables from the winch in the Seldén MCU in the order displayed (Grey=L3, Brown=L2, Orange=L1).

If needed, the cables can be cut to length before crimping.

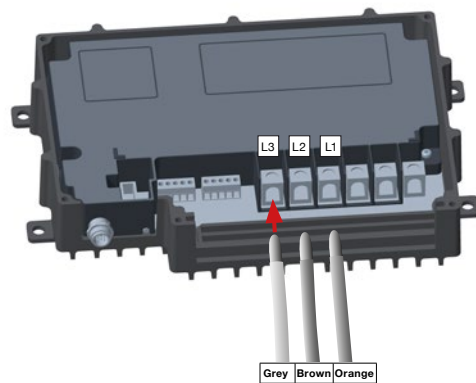

3.3 Adjusting the Self-tailing arm

The self-tailing arm can be adjusted to feed the line into the cockpit. To do this, disassemble the winch according to chapter 6.1, step 1 by unscrewing the three (3) screws holding the top cover. This allows the ST-arm to be adjusted, an illustration of this is shown below.

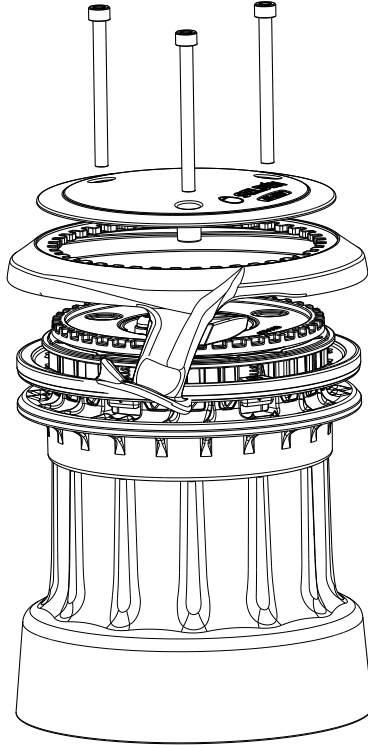

- ! Beware of any interference between the load and non load end of the line while operating the winch. Adjustment of the self-tailing arm may be needed to avoid any interference.

3.4 Control button installation and configuration

- ! It is recommended to place the primary buttons close to the winch and oriented so that risk of unintentional activation (e.g. from standing/sitting) is low. Installation instruction for control buttons and SEL-Bus converter is found in manual 597-275-E, chapter 2.4 “Installing the push buttons”, and in the product sheet for each respective push button.

Configuration

The buttons are connected to the Seldén SEL-Bus system via a SEL-Bus converter. The SEL-Bus converter can be configured to any unit in the SEL-Bus network. To configure primary and auxiliary buttons to the winch MCU, please view installation manual 597-275-E, chapter 2.7 “Configuration of control buttons to SEL-Bus network”.

4 Operation

4.1 Normal operation

Winching with 3-speed control

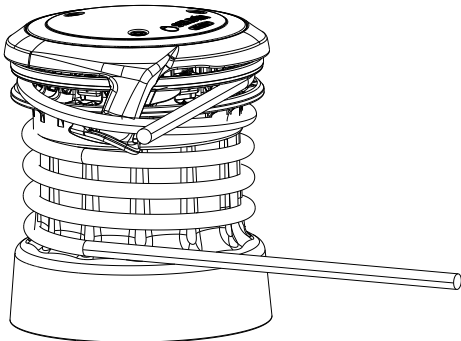
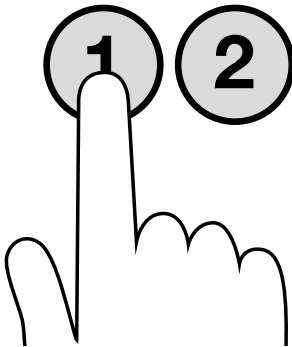
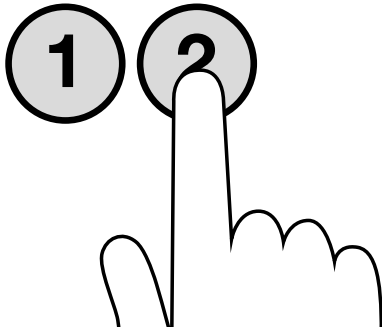
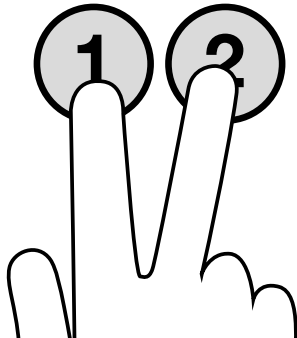
| | |
|--|--|
| <p>Apply the line 3-4 turns clockwise around the winch, over the self-tailing arm and securing it into the self-tailing jaws. Make sure the line does not come loose from the self-tailing jaws under use.</p> |  |
| <p>Press button "1" to engage the winch at the low-speed setting.</p> |  |
| <p>Press button "2" to engage the winch at the intermediate-speed setting.</p> |  |
| <p>Press button "1+2" in either order, to engage the winch at the high-speed setting.</p> |  |
| <p>To stop winching, release the buttons completely.</p> | |

It is recommended to always start the winching sequence by pressing button “1” to verify the sail and/or line feeds properly. Once this is confirmed, button “2” or “1+2” can be pushed to increase the speed.



High-speed winching is hazardous and increases the chance of injury and/or damage to boat or equipment. While winching be advised to constantly check for proper hoisting of the sail and/or lines to and from the winch and in the mast to avoid any damages.

4.2 Pairing with an electric furling mast as outhaul-winch

If the winch is installed as a synchronized outhaul winch, the winch work both as an ordinary winch (controlled by the winch speed buttons, 1 and 2) and as a synchronized outhaul winch, starting simultaneously with the furling mast motor when the main sail “out” button is pressed. This feature is programmed in the special synchronization control chip (in the winch MCU) and can be purchased retrospectively to update a basic winch.



Before attempt to **unfurl** the mainsail, apply the **outhaul** to the winch according to chapter 4.1 of this manual. Always verify that no other line, body parts or loose items are close to the winch prior to and during unfurling.



When paired with an electric furling mast, the winch will sound an audible attention signal when pressing the control button (“out”) for the electric furling mast. The signal indicates that the winch is going to start turning.



Before attempt to furl the mainsail, verify that the outhaul is released from the self-tailing arm as the winch will not rotate. A half turn can in most conditions preferably be kept on the winch to facilitate a controlled release of the outhaul during furling.



Pairing with a Seldén electric furling mast, does not otherwise affect the use of the E40i electric winch when controlled by the designated winch only control buttons.

For further information about Synchronized Main Furling, see manual ”Electric furling mast 597-460-E”.

4.3 Emergency situations

Loss of power, diverting the line

As the E40i electric winch is only operational by electric power it should always be paired with at least one other manually operational winch. In the case of power-loss the line can be diverted onto this other winch and winching can resume manually. An example of this is shown in the picture below.

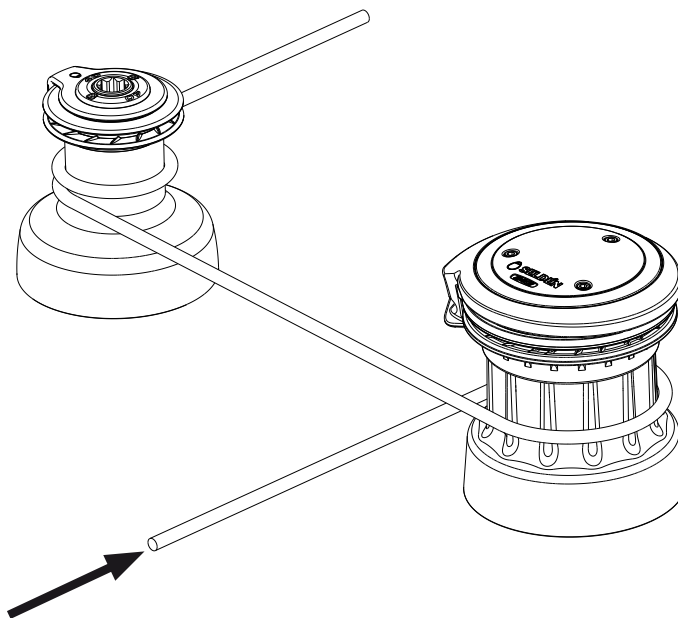

Any strength evaluation of the load bearing capacity of the hull and/or deck is made by the user and Seldén Mast AB cannot be held responsible for any damages, failed equipment or injuries obtained as a result of any improper line diversion.

5 Trouble shooting

| Problem | Cause | Solution |
|--|---|---|
| When pressing the controlbutton, the winch drum oscillates back and forth in small increments instead of spinning. | Connection of the winch is faulty at the MCU. | Reinstall the wires connecting the winch at the MCU in the proper order according to chapter 3.2, step 13. |
| Winch does not run at all. | Improper installation of SEL-Bus network, MCU or PSU. | Verify any fault- or error-codes displayed on the MCU or PSU. These are displayed as a flashing sequence in a LED light close to the SEL-bus connection cables on both the MCU and PSU. For further help in diagnosing and trouble-shooting the issue, please refer to manual 597-275-E. |

6 Service and maintenance

6.1 Frequent maintenance

Selden recommends this type of maintenance to be performed any number of times and with any interval but at least two (2) times annually.

1.

Unscrew the three (3) screws visible at the top of the winch using the 5mm Allen-key. Remove the screws, the top cover and the self-tailing arm.

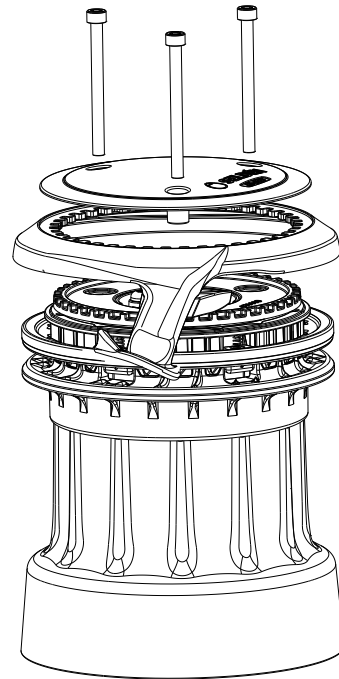

2.

Continue by removing the locator bracket and the drum-assembly.

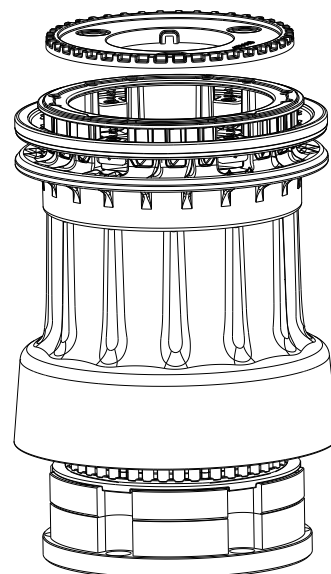

3.

Remove the roller-bearing and the washer. Follow this by unscrewing the five (5) screws locking the centre hub to the base. Depending on the version of the winch, this is done using a hexalobular key size T30 or a 5mm Allen-key.

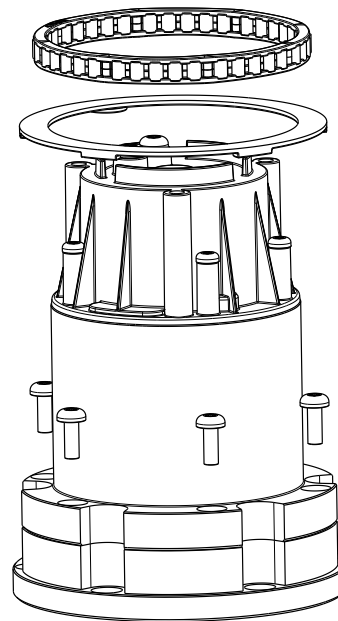

4.

Carefully lift and flip the centre hub to access the gears.

This may require the cables to be un-hinged from the cable-retention system protecting the cables from interference with ratchet driveshaft gear.

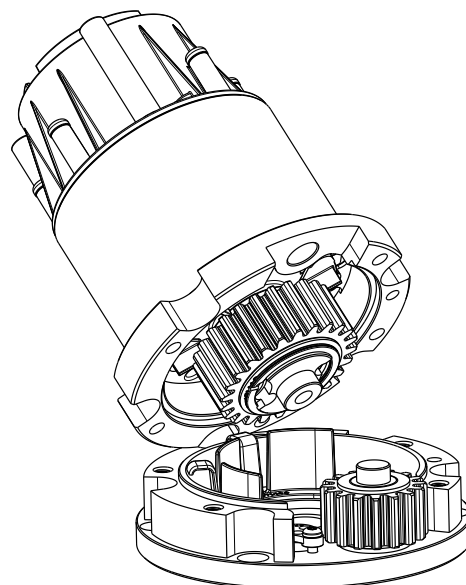

5.

Place the centre hub close to the base.

Be advised, to protect any sensitive surfaces of the deck or coach-roof, such as a wooden deck, by placing a cloth or similar between the deck and the centre hub.

Proceed to inspect the functionality of all gears and ratchet mechanism. If needed, clean and/or replace any worn parts such as springs, pawls or pawl holders.

Further information on how to access these parts for maintenance can be viewed in the next chapter.

Wipe off any old grease and apply Seldén lubrication grease to the gears and apply Seldén pawl oil to lubricate the pawls.

Re-assemble the winch.

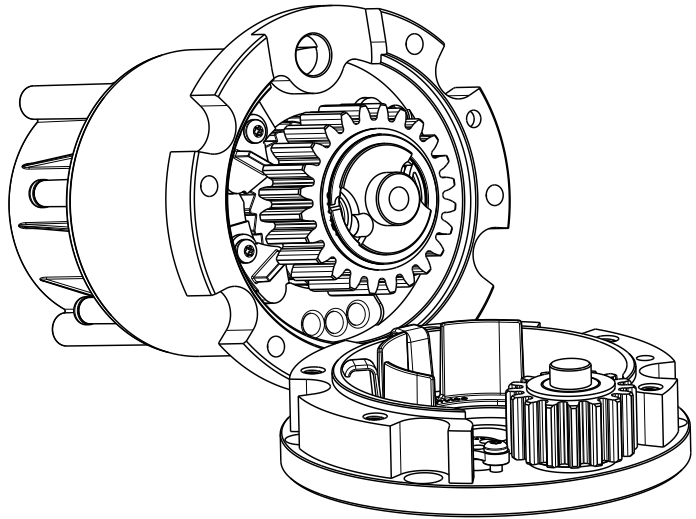

6.2 Extended maintenance

Seldén recommends this type of maintenance to be performed any number of times and with any interval but at least one (1) time every second (2nd) year.

1.

Follow all the steps in chapter 6.1, Frequent maintenance.

2.

Access the drive gear ratchet mechanism by removing the circlip and the plastic washer. Then remove the gear. Pay attention, as the pawls and springs might shift during this operation and may get lost if allowed to move during removal of the gear.

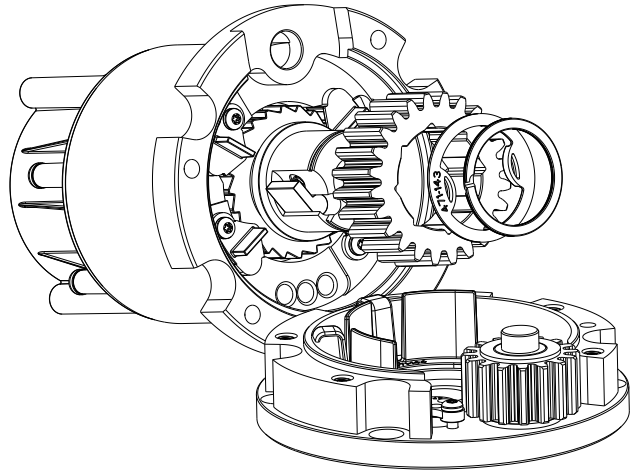

3.

Remove the four (4) screws and the pawl-holders for the second ratchet mechanism. Remove the pawls and springs from the ratchet driveshaft and clean all parts and gears thoroughly using a mild degreaser.

Replace any worn springs, pawls and holders.

Lubricate all pawls using Seldén pawl oil and apply Seldén lubrication grease to the gears.

Re-assemble the winch.

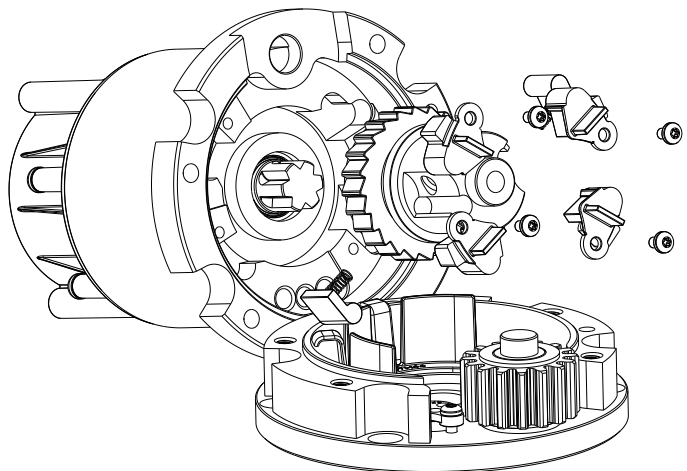

6.3 Professional Maintenance

Selden recommends this type of maintenance to be performed every five (5) years or after 1000h use, whichever comes first.

Motor and gear house maintenance

This maintenance includes replacing oil, seals and gearbox parts and shall only be carried out by authorized Seldén staff.

1.

Follow all steps in chapter 6.1 Frequent maintenance

2.

Make sure all power to the SEL-bus system has been disabled. Decouple the cables from the winch MCU..

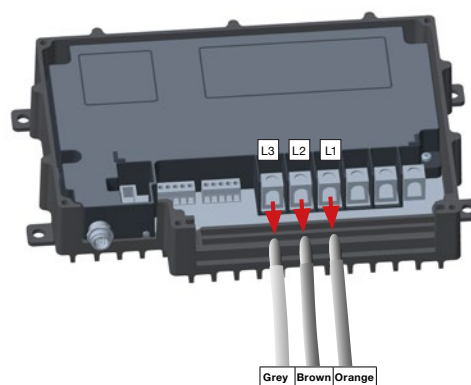

3.

Unscrew the two cable retention screws to release the retention bracket to allow the cables to be fed through the deck.

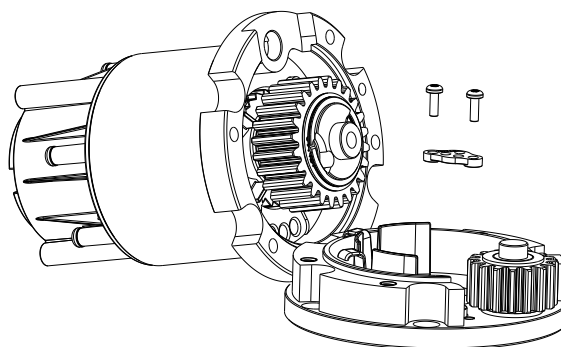

4.

Carefully feed the cables out through the deck or coach roof, one by one to completely release the winch.

5.

Wrap the cables around the centre hub and package these carefully. Send these parts to be serviced and refitted by Seldén.

When the refit is complete and the centre hub has been returned, the winch can be reassembled.

7 Spare parts

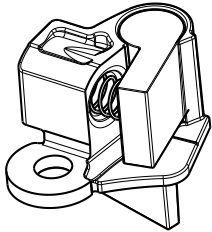
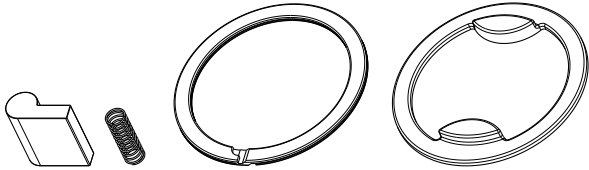
| Description | Art. No. | |
|---------------------------------|-------------|--|
| Pawl and holder replacement kit | 471-057-10R |  <p>(4 pc)</p> |
| Drive-gear pawl replacement kit | 471-143-10R |  <p>(2 pc) (2 pc)</p> |

8 Disposal

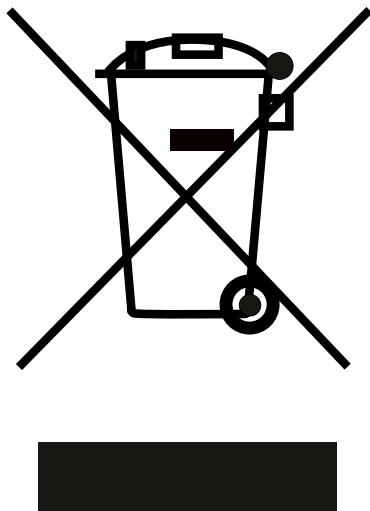

The crossed out wheeled bin symbol on the product means that used electrical and electronic equipment (WEEE) should not be mixed with general household waste. For proper treatment, recovery and recycling, please take this product(s) to designated collection points where it will be accepted free of charge. Alternatively, in some countries, you may be able to return your products to your local retailer upon purchase of an equivalent new product.

Disposing of this product correctly will help save valuable resources and prevent any potential negative effects on human health and the environment, which could otherwise arise from inappropriate waste handling.

Please contact your local authority for further details of your nearest designated collection point.

9 Warranty

Seldén Mast AB guarantees the E40i winch for 2 years. The guarantee covers faults arising from defective design, materials or workmanship.

The guarantee is only valid if the product is assembled, operated and maintained in accordance with this manual and is not subjected to loads in excess of those indicated in the brochure and on the Seldén website.

Complete shipment and warranty conditions are to be found on Seldéns website www.seldenmast.com. See Resources/Partners information/General information/General conditions of sale (595-546-E).

If the system is repaired or modified by anyone other than Seldén Mast AB or one of our authorized dealers, the guarantee ceases to be valid.

Seldén Mast AB reserves the right to alter the content and design without prior warning.

DINGHIESKEELBOATSYACHTS

*Seldén Mast AB, Sweden
Tel +46 (0)31 69 69 00
Fax +46 (0)31 29 71 37
e-mail info@seldenmast.com*

*Seldén Mast Limited, UK
Tel +44 (0) 1329 504000
Fax +44 (0) 1329 504049
e-mail info@seldenmast.co.uk*

*Seldén Mast Inc., USA
Tel +1 843-760-6278
Fax +1 843-760-1220
e-mail info@seldenus.com*

*Seldén Mast A/S, DK
Tel +45 39 18 44 00
Fax +45 39 27 17 00
e-mail info@seldenmast.dk*

*Seldén Mid Europe B.V., NL
Tel +31 (0) 111-698 120
Fax +31 (0) 111-698 130
e-mail info@seldenmast.nl*

*Seldén Mast SAS, FR
Tel +33 (0) 251 362 110
Fax +33 (0) 251 362 185
e-mail info@seldenmast.fr*

www.seldenmast.com

Dealer:

The Seldén Group is the world's leading manufacturer of masts and rigging systems in carbon and aluminium for dinghies, keelboats and yachts. The Group consists of Seldén Mast AB in Sweden, Seldén Mast A/S in Denmark, Seldén Mast Ltd in the UK, Seldén Mid Europe B.V. in the Netherlands, Seldén Mast Inc in the USA and Seldén Mast in France. Our well known brands are Seldén and Furlex. The worldwide success of Furlex has enabled us to build a network of over 750 authorised dealers covering the world's marine markets. So wherever you sail, you can be sure of fast access to our service, spare parts and know-how.



www.seldenmast.com