

TECHNICAL SPECIFICATIONS

CMCE-DIAMOND

Definition

The CMCE-MARINE is a lightning protection system designed to prevent the formation of lightning strikes. Its operating principle is based on stabilizing and compensating the variable electric field present in its surroundings, thereby inhibiting the development of the upward tracer.

Maximum Operating Voltage of the CMCE-MARINE (without atmospheric discharge)

Rated at 840 kV at one meter, according to high-voltage laboratory tests (UNE 21186:2011 // NF C17-102:2011).

Maximum Admissible Short-Circuit Current

Tests conducted following IEC 10/350 μ s power curves, with a peak current I_{pico} (kA) [100 kA \pm 10%], as specified in IEC 62305, demonstrate that the device can withstand seven consecutive discharges of: 89.90 kA; 89.62 kA; 88.53 kA; 89.30 kA; 90.44 kA; 96.65 kA; 89.68 kA; without material failure, deterioration marks, or perforation.

Product Warranty

Requires annual maintenance or according to the frequency established by the manufacturer based on the characteristics of the vessel.

Maintenance is mandatory and must be performed and certified by the authorized installer. Includes a 5-year warranty against manufacturing defects, provided that maintenance is carried out according to the established schedule.

Protection Efficiency

Provides a 99% reduction in direct lightning strikes to the protected structure.

In the event of a direct strike (1%) or indirect effects caused by externally induced overvoltages, the CMCE-MARINE acts as a thermal fuse, absorbing lightning energy as heat through the melting of its internal components, reducing voltage levels (between 60% and 90%) and mitigating electromagnetic effects.

Materials

High-purity aluminum.

Insulator: Polyacetal (POM), also known as polyoxymethylene.

Contains no electronic components, heavy metals, or radioactive materials.



Connection System for the Manufactured Mast Support:

Support:

The device includes a central-axis mounting system for attachment to the support. The CMCE-MARINE requires a support with an internal diameter of 42 mm. For a manufactured support, it must have a minimum wall thickness of 3.2 mm (this may vary depending on the model; consult the manufacturer for more information).

To secure the CMCE to the support, the unit features two through-holes: the first is a $\varnothing 10$ mm hole located 31 mm from the edge of the support, and the second is a $\varnothing 10$ mm hole located 51 mm from the edge of the support.

CMCE Product Certification:

- Lloyd's Register Approval Certificate LR2514641TA
- RINA Type Approval Certificate ELE281223XG
- Compliant with IEC, EN, UNE-EN, and BS-EN 62305 Parts 1, 2, 3, and 4
- Compliant with UL 96 (for specific device)
- RoHS compliant
- CE marking
- UKCA marking
- ISO 9001:2015 and ISO 14001:2015 certifications
- Compliance with the Commonwealth of Independent States (CIS)
- Approved by the TESLA Institute in accordance with IEC 60060-1:2010 and IEC 60060-2:2010

SERTEC S.R.L. is approved within the NATO Codification System (NCS) with the NCAGE code SFKU3 for CMCE SERTEC lightning protection devices.

DUNS registration number: 955067967

ITE laboratory testing under UNE 21186:2011 / NFC 17102:2011 (ENAC-ILAC accredited laboratories, ISO 17025):

- High-voltage impulse tests reaching up to 840 kV at one meter without tracer formation.
- Mechanical and environmental testing: UNE 60068-2-52, sulfurous atmosphere, current, and triggering advance.

Studies conducted at GCC-LAB (Saudi Arabia) under IEC 62305.

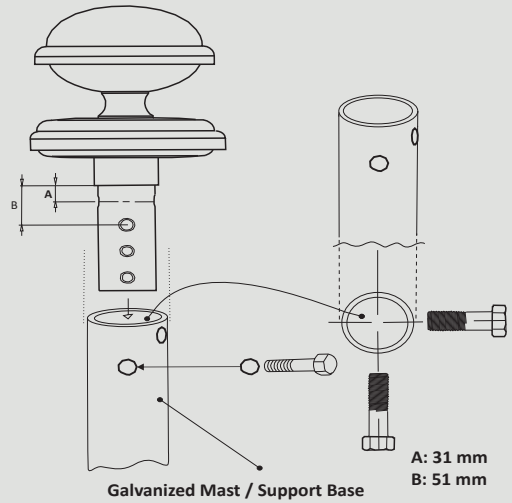

TECHNICAL SPECIFICATIONS CMCE-DIAMOND

Operating Principle:

Compensation of the surrounding electric field. Through its high-efficiency capacitor system, the device prevents electrical discharge.

Maximum Operating Voltage Without Discharge:

Maximum working electric field 840 kV/m.

Maximum Current:

Tested at 100 kA according to IEC 10/350 μ s under IEC 62305 for the CMCE-MARINE.

Applications:

With a high deionizing capability, it is designed to provide maximum protection on Yachts,
Cruise Ships, Catamarans, Cargo Vessels, Military Ships, and more.



CMCE-DIAMOND

379.00

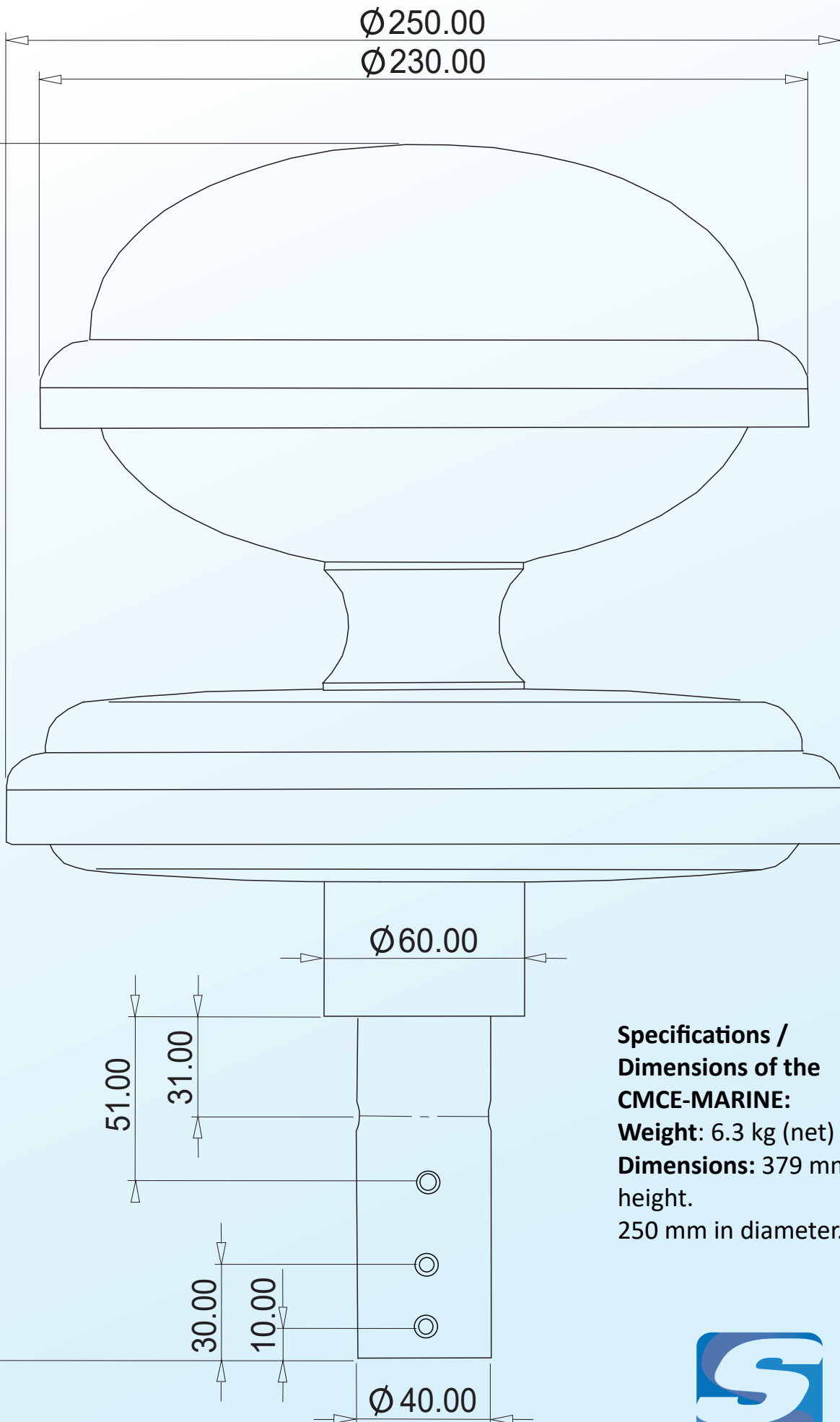

**Specifications /
Dimensions of the
CMCE-MARINE:**

Weight: 6.3 kg (net)

Dimensions: 379 mm in
height.

250 mm in diameter.